

KEITHLEY

**Model 7071-4 General Purpose Dual 4 × 12
Matrix Card
Instruction Manual**

Contains Operating and Servicing Information

Publication Date: October 1988

Document Number: 7071-4-901-01 Rev. A

WARRANTY

Keithley Instruments, Inc. warrants this product to be free from defects in material and workmanship for a period of 1 year from date of shipment.

Keithley Instruments, Inc. warrants the following items for 90 days from the date of shipment: probes, cables, rechargeable batteries, diskettes, and documentation.

During the warranty period, we will, at our option, either repair or replace any product that proves to be defective.

To exercise this warranty, write or call your local Keithley representative, or contact Keithley headquarters in Cleveland, Ohio. You will be given prompt assistance and return instructions. Send the product, transportation prepaid, to the indicated service facility. Repairs will be made and the product returned, transportation prepaid. Repaired or replaced products are warranted for the balance of the original warranty period, or at least 90 days.

LIMITATION OF WARRANTY

This warranty does not apply to defects resulting from product modification without Keithley's express written consent, or misuse of any product or part. This warranty also does not apply to fuses, software, non-rechargeable batteries, damage from battery leakage, or problems arising from normal wear or failure to follow instructions.

THIS WARRANTY IS IN LIEU OF ALL OTHER WARRANTIES, EXPRESSED OR IMPLIED, INCLUDING ANY IMPLIED WARRANTY OF MERCHANTABILITY OR FITNESS FOR A PARTICULAR USE. THE REMEDIES PROVIDED HEREIN ARE BUYER'S SOLE AND EXCLUSIVE REMEDIES.

NEITHER KEITHLEY INSTRUMENTS, INC. NOR ANY OF ITS EMPLOYEES SHALL BE LIABLE FOR ANY DIRECT, INDIRECT, SPECIAL, INCIDENTAL OR CONSEQUENTIAL DAMAGES ARISING OUT OF THE USE OF ITS INSTRUMENTS AND SOFTWARE EVEN IF KEITHLEY INSTRUMENTS, INC., HAS BEEN ADVISED IN ADVANCE OF THE POSSIBILITY OF SUCH DAMAGES. SUCH EXCLUDED DAMAGES SHALL INCLUDE, BUT ARE NOT LIMITED TO: COSTS OF REMOVAL AND INSTALLATION, LOSSES SUSTAINED AS THE RESULT OF INJURY TO ANY PERSON, OR DAMAGE TO PROPERTY.

The logo for Keithley Instruments, featuring the word "KEITHLEY" in a bold, white, sans-serif font inside a black rectangular box.

Keithley Instruments, Inc. • 28775 Aurora Road • Cleveland, OH 44139 • 216-248-0400 • Fax: 216-248-6168 • <http://www.keithley.com>

CHINA:	Keithley Instruments China • Yuan Chen Xin Building, Room 705 • No. 12 Yumin Road, Dewai, Madian • Beijing, China 100029 • 8610-2022886 • Fax: 8610-2022892
FRANCE:	Keithley Instruments SARL • BP 60 • 3 allée des Garays • 91122 Palaiseau Cédex • 31-6-0115155 • Fax: 31-6-0117726
GERMANY:	Keithley Instruments GmbH • Landsberger Straße 65 • 82110 Germering • 49-89-849307-0 • Fax: 49-89-84930759
GREAT BRITAIN:	Keithley Instruments, Ltd. • The Minster • 58 Portman Road • Reading, Berkshire RG30 1EA • 44-01734-575666 • Fax: 44-01734-596469
ITALY:	Keithley Instruments SRL • Viale S. Gimignano 38 • 20146 Milano • 39-2-48303008 • Fax: 39-2-48302274
JAPAN:	Keithley KK • Aibido Bldg. • 7-20-2 Nishishinjuku • Shinjuku-ku, Tokyo 160 • 81-3-5389-1964 • Fax: 81-3-5389-2068
NETHERLANDS:	Keithley Instruments BV • Avlingen West 49 • 4202 MS Gorinchem • 31-(0)183-635333 • Fax: 31-(0)183-630821
SWITZERLAND:	Keithley Instruments SA • Kriesbachstrasse 4 • 8600 Dübendorf • 41-1-8219444 • Fax: 41-1-8203081
TAIWAN:	Keithley Instruments Taiwan • 1, Ming-Yu First Street • Hsinchu, Taiwan, R.O.C. • 886-35-778462 • Fax: 886-35-778455

**Instruction Manual
Model 7071-4
General Purpose Dual 4 × 12 Matrix Card**

©1988, Keithley Instruments, Inc.
Instruments Division
Cleveland, Ohio, U.S.A.
Document Number 7071-4-901-01

All Keithley products are trademarks or registered trademarks of Keithley Instruments, Inc.

Other brand and product names are trademarks or registered trademarks of their respective holders.

SAFETY PRECAUTIONS

The following safety precautions should be observed before using the Model 7071-4 and the associated instruments.

This matrix card is intended for use by qualified personnel who recognize shock hazards and are familiar with the safety precautions required to avoid possible injury. Read over this manual carefully before using the matrix card.

ALWAYS remove power from the entire system (Model 707, test instruments, DUT, etc.) and discharge any capacitors before doing any of the following:

1. Installing or removing the matrix card from the mainframe.
2. Connecting or disconnecting cables from the matrix card. The pins of the Model 7078-MTC cable connectors are easily accessible making them extremely hazardous to handle while power is applied.
3. Making internal changes to the card (such as removing or installing jumpers and quick-disconnect terminal blocks).

Exercise extreme caution when a shock hazard is present at the test fixture. User-supplied lethal voltages may be present on the fixture or the connector jacks. The American National Standards Institute (ANSI) states that a shock hazard exists when voltage levels greater than 30V RMS or 42.4V peak are present. A good safety practice is to expect that hazardous voltage is present in any unknown circuit before measuring.

Do not exceed 200V between any two pins or between any pin and earth ground.

Inspect the connecting cables and test leads for possible wear, cracks, or breaks before each use.

For maximum safety, do not touch the test fixture, test cables or any instruments while power is applied to the circuit under test.

Do not touch any object which could provide a current path to the common side of the circuit under test or power line (earth) ground.

Do not exceed the maximum signal levels of the test fixture, as defined in the specifications and operation section of this manual.

Do not connect the matrix card directly to unlimited power circuits. This product is intended to be used with impedance limited sources. NEVER connect the matrix card directly to ac mains.

When connecting sources, install protective devices to limit fault current and voltage to the card.

The chassis connections on the PC board (located behind the front panel of the matrix card) must only be used as shield connections for measuring circuits, NOT as safety earth ground connections.

7071-4 General Purpose Dual 4×12 Matrix Card

MATRIX CONFIGURATION: Dual 4 rows by 12 columns. Also configurable as 8 rows by 12 columns or 4 rows by 24 columns.

CROSSPOINT CONFIGURATION: 3 pole Form A (HI, LO, GUARD).

CONNECTOR TYPE: Quick disconnect using 38 pin connectors. In addition, screw terminals are available on rows.

MAXIMUM SIGNAL LEVEL: 200V, 1A carry/0.5A switched, 10VA peak (resistive load).

COMMON MODE VOLTAGE: 200V maximum between any 2 pins or chassis.

CONTACT LIFE:
Cold Switching: 10^8 closures.
At Maximum Signal Level: 10^5 closures.

PATH RESISTANCE (per conductor): $<0.50\Omega$ initial, $<1.5\Omega$ at end of contact life.

CONTACT POTENTIAL: $<5\mu\text{V}$ per crosspoint (HI to LO, <1 minute after actuation).

OFFSET CURRENT: $<100\text{pA}$ (HI to LO).

ISOLATION:
Path: $>10^3\Omega$, $<10\text{pF}$, $>40\text{dB}$ at 1MHz, $1\text{M}\Omega$ load.
Differential: $10^9\Omega$, 45pF nominal.
Common Mode: $10^9\Omega$, 300pF nominal.

INSERTION LOSS (1MHz, 50Ω source, $1\text{M}\Omega$ load): 0.1dB typical.

3dB BANDWIDTH ($1\text{M}\Omega$ load): 5MHz typical.

RELAY DRIVE CURRENT (per crosspoint): 15mA.

RELAY SETTling TIME: $<3\text{msec}$.

ENVIRONMENT:

Operating: 0° to 50°C , up to 35°C @ 70% R.H.

Storage: -25° to 65°C .

ACCESSORIES SUPPLIED: Instruction manual, screw terminal adapter for 4×24 configuration.

ACCESSORIES AVAILABLE:

Model 7078-CIT: Contact Insertion and Extraction Tools

Model 7078-HCT: Hand Crimping Tool

Model 7078-KIT: Mass Terminated Plug with Contacts

Model 7078-MTC-5: Mass Terminated Cable Assembly, 1.5m (5 ft.)

Model 7078-MTC-20: Mass Terminated Cable Assembly, 6m (20 ft.)

Model 7078-MTR: Mass Terminated Receptacle with Contacts

Specifications subject to change without notice.

Table of Contents

SECTION 1—GENERAL INFORMATION

1.1	INTRODUCTION	1-1
1.2	FEATURES	1-1
1.3	WARRANTY INFORMATION	1-1
1.4	MANUAL ADDENDA	1-1
1.5	SAFETY SYMBOLS AND TERMS	1-1
1.6	SPECIFICATIONS	1-2
1.7	UNPACKING AND INSPECTION	1-2
1.7.1	Inspection for Damage	1-2
1.7.2	Shipping Contents	1-2
1.7.3	Instruction Manual	1-2
1.8	REPACKING FOR SHIPMENT	1-2
1.9	OPTIONAL ACCESSORIES	1-3

SECTION 2—OPERATION

2.1	INTRODUCTION	2-1
2.2	HANDLING PRECAUTIONS	2-1
2.3	CARD INSTALLATION AND REMOVAL	2-2
2.4	BASIC MATRIX CONFIGURATIONS	2-4
2.5	TYPICAL MATRIX SWITCHING SCHEMES	2-10
2.6	CONNECTION METHODS	2-11
2.7	MATRIX EXPANSION	2-23
2.8	TYPICAL CONNECTION SCHEMES	2-27

SECTION 3—APPLICATIONS

3.1	INTRODUCTION	3-1
3.2	THICK FILM RESISTOR NETWORK TESTING	3-1
3.2.1	Four-terminal Ohms Measurements	3-2
3.2.2	Voltage Divider Checks	3-3
3.3	TRANSISTOR TESTING	3-5
3.3.1	Current Gain Checks	3-6
3.3.2	I and V Measurements	3-6

SECTION 4—SERVICE INFORMATION

4.1	INTRODUCTION	4-1
4.2	HANDLING AND CLEANING PRECAUTIONS	4-1
4.3	RELAY TEST PROGRAM SET-UP	4-1
4.4	PERFORMANCE VERIFICATION	4-2
4.4.1	Environmental Conditions	4-3

4.4.2	Recommended Equipment	4-3
4.4.3	Initial Preparation	4-3
4.4.4	Path Resistance Tests	4-3
4.4.5	Offset Current Tests	4-5
4.4.6	Contact Potential Tests	4-6
4.4.7	Path Isolation Tests	4-7
4.4.8	Differential and Common Mode Isolation Tests	4-9
4.5	PRINCIPLES OF OPERATION	4-13
4.5.1	Card Identification	4-13
4.5.2	Switching Circuitry	4-13
4.5.3	Power Up Safeguard	4-13
4.6	SPECIAL HANDLING OF STATIC-SENSITIVE DEVICES	4-14
4.7	TROUBLESHOOTING	4-14
4.7.1	Recommended Equipment	4-14
4.7.2	Troubleshooting Procedure	4-16

SECTION 5—REPLACEABLE PARTS

5.1	INTRODUCTION	5-1
5.2	PARTS LIST	5-1
5.3	ORDERING INFORMATION	5-1
5.4	FACTORY SERVICE	5-1
5.5	COMPONENT LAYOUT AND SCHEMATIC DIAGRAM	5-1

List of Illustrations

SECTION 2—OPERATION

Figure 2-1	Matrix Card Installation	2-3
Figure 2-2	Cable Clamp Assembly	2-4
Figure 2-3	Model 7071-4	2-6
Figure 2-4	Simplified Component Layout	2-7
Figure 2-5	Model 7071-4 Configured as 4 × 24 Matrix	2-8
Figure 2-6	Model 7071-4 Configured as 8 × 12 Matrix	2-9
Figure 2-7	Column Jumper (1 of 12)	2-10
Figure 2-8	Single-ended Switching Example (Guard Used as Shield)	2-10
Figure 2-9	Differential Switching Example (Shielded)	2-10
Figure 2-10	Driven Guard Example (Shielded)	2-11
Figure 2-11	Sensing Example (Shielded)	2-12
Figure 2-12	Connections Using Three Model 7078-MTC Cables	2-13
Figure 2-13	Connecting Plug to Receptacle	2-14
Figure 2-14	Receptacle Contact Assignments	2-15
Figure 2-15	Connections Using One Model 7078-MTC Cable Cut in Half	2-17
Figure 2-16	Cable Preparation	2-18
Figure 2-17	Connecting Belden 9734 Cable to Plug	2-19
Figure 2-18	Cable Position	2-19
Figure 2-20	Terminal Block Connections	2-21
Figure 2-21	Pre-wired Quick Disconnect Terminal Assembly for 4 × 24 Matrix Configuration	2-22
Figure 2-22	Narrow Matrix Example (4 × 72)	2-23
Figure 2-23	Dual 4 × 72 Matrices	2-24
Figure 2-24	Wide Matrix Example (8 × 36)	2-25
Figure 2-25	Partial Matrix Expansion (8 × 36)	2-26
Figure 2-26	Single Card System Example	2-28
Figure 2-27	Multiple Card System Example	2-29
Figure 2-28	Multiple Mainframe Example	2-30
Figure 2-29	Matrix/Multiplexer System	2-31

SECTION 3—APPLICATIONS

Figure 3-1	Thick Film Resistor Network Testing	3-1
Figure 3-2	Four-terminal Ohms Measurements	3-2
Figure 3-3	Voltage Divider Checks	3-4
Figure 3-4	Transistor Testing	3-5

Figure 3-5	Transistor Current Gain Checks	3-7
Figure 3-6	Common-Emitter Characteristics of an NPN Silicon Transistor	3-8
Figure 3-7	Transistor I_E Measurements	3-9
Figure 3-8	Transistor V_{BE} Measurements	3-10

SECTION 4—SERVICE INFORMATION

Figure 4-1	Relay Test Setup	4-2
Figure 4-2	Path Resistance Testing	4-4
Figure 4-3	Differential Offset Current Testing	4-5
Figure 4-4	Common Mode Offset Current Testing	4-6
Figure 4-5	Contact Potential Testing	4-7
Figure 4-6	Path Isolation Testing (Guarded)	4-8
Figure 4-7	Differential Isolation Testing	4-11
Figure 4-8	Common Mode Isolation Testing	4-12
Figure 4-9	IDDATA Timing Diagram	4-13
Figure 4-10	Receptacle Contact Identification	4-15
Figure 4-11	Rear Shield	4-17

List of Tables

SECTION 2—OPERATION

Table 2-1	Column Number Assignments	2-4
Table 2-2	4 × 24 Matrix Crosspoint Assignments	2-5
Table 2-3	Model 7071-4 Available Accessories	2-14
Table 2-4	Model 7078-MTC Wire Identification	2-16
Table 2-5	Narrow Matrix Expansion	2-23
Table 2-6	Wide Matrix Expansion	2-24

SECTION—SERVICE INFORMATION

Table 4-1	Verification Equipment	4-3
Table 4-2	Path Isolation Tests	4-9
Table 4-3	Differential and Common Mode Isolation Test	4-10
Table 4-4	Recommended Troubleshooting Equipment	4-14
Table 4-5	Troubleshooting Summary	4-16

SECTION 1

General Information

1.1 INTRODUCTION

This section contains general information about the Model 7071-4 Dual 4 × 12 General Purpose Matrix Card and is arranged in the following manner:

1.2 Features

1.3 Warranty Information

1.4 Manual Addenda

1.5 Safety Symbols and Terms

1.6 Specifications

1.7 Unpacking and Inspection

1.8 Repacking for Shipment

1.9 Optional Accessories

1.2 FEATURES

The Model 7071-4 is a general purpose, three-pole, dual 4 × 12 (four row by 12 column) matrix card. Some of the key features include:

- Guard capability. Each HI/LO path pair on the PC board is surrounded by a third path that can be used for guarding.
- Low contact potential and offset current for minimal effects on low-level signals.
- Quick disconnects using the “rack and panel” receptacles on the rear panel or terminal blocks (for rows) on the PC board.
- Row backplane jumpers. Cutting jumpers disconnects rows from the Model 707 backplane.

- Column jumpers. Installing jumpers configures card as an 8 × 12 matrix.
- Pre-wired terminal block assembly. Installing this assembly configures the card as a 4 × 24 matrix.

1.3 WARRANTY INFORMATION

Warranty information is located on the inside front cover of this instruction manual. Should your Model 7071-4 require warranty service, contact the Keithley representative or authorized repair facility in your area for further information. When returning the matrix card for repair, be sure to fill out and include the service form at the back of this manual in order to provide the repair facility with the necessary information.

1.4 MANUAL ADDENDA

Any improvements or changes concerning the matrix card or manual will be explained in an addendum included with the unit. Be sure to note these changes and incorporate them into the manual.

1.5 SAFETY SYMBOLS AND TERMS

The following symbols and terms may be found on an instrument or used in this manual.

The symbol  on an instrument indicates that the user should refer to the operating instructions located in the instruction manual.

The symbol  on an instrument shows that high voltage may be present on the terminal(s). Use standard safety precautions to avoid personal contact with these voltages.

The **WARNING** heading used in this manual explains dangers that might result in personal injury or death. Always read the associated information very carefully before performing the indicated procedure.

The **CAUTION** heading used in this manual explains hazards that could damage the matrix card. Such damage may invalidate the warranty.

1.6 SPECIFICATIONS

Model 7071-4 specifications may be found at the front of this manual. These specifications are exclusive of the matrix mainframe specifications.

1.7 UNPACKING AND INSPECTION

1.7.1 Inspection for Damage

The Model 7071-4 is packaged in a re-sealable, anti-static bag to protect it from damage due to static discharge and from contamination that could degrade its performance. Before removing the card from the bag, observe the following precautions on handling.

Handling Precautions:

1. Always grasp the card by the handle and side edges. Do not touch the edge connectors and do not touch board surfaces or components.
2. When not installed in a Model 707 mainframe, keep the card in the anti-static bag and store in the original packing carton.

After removing the card from its anti-static bag, inspect it for any obvious signs of physical damage. Report any such damage to the shipping agent immediately.

If you are going to install the card in the Model 707 mainframe at this time, be sure to follow the additional handling precautions explained in paragraph 2.2.

1.7.2 Shipping Contents

The following items are included with every Model 7071-4 order:

- Model 7071-4 General Purpose Matrix Card.
- Pre-wired terminal block assembly (4 × 24 matrix).
- 20 column jumper sets.
- Model 7071-4 Instruction Manual.
- Additional accessories as ordered. Note that the Model 7078-MTC may be shipped in a separate packing carton.

1.7.3 Instruction Manual

The Model 7071-4 Instruction Manual is three-hole drilled so that it can be added to the three-ring binder of the Model 707 Switching Matrix Instruction Manual. After removing the plastic wrapping, place the manual in the binder after the mainframe instruction manual. Note that a manual identification tab is included and should precede the matrix card instruction manual.

If an additional instruction manual is required, order the manual package, Keithley part number 7071-4-901-00. The manual package includes an instruction manual and any pertinent addenda.

1.8 REPACKING FOR SHIPMENT

Should it become necessary to return the Model 7071-4 for repair, carefully pack the unit in its original packing carton or the equivalent, and include the following information:

- Advise as to the warranty status of the matrix card.
- Write ATTENTION REPAIR DEPARTMENT on the shipping label.
- Fill out and include the service form located at the back of this manual.

1.9 OPTIONAL ACCESSORIES

The following accessories are available for use with the Model 7071-4.

Model 7078-CIT Contact Insertion and Extraction Tools

The Model 7078-CIT contains an insertion tool that is used to insert wire crimp tail contacts into “rack and panel” plugs and receptacles. Conversely, the extraction tool is used for the removal of the contacts.

Model 7078-HCT Hand Crimping Tool

The Model 7078-HCT is used to attach wire crimp tail contacts to #18 to #26 AWG stranded wire.

Model 7078-KIT Connector Kit (Plug)

The Model 7078-KIT contains the parts to assemble one “rack and panel” plug. This plug will mate to either the ROWS or COLUMNS receptacle on the rear panel of the card. Parts contained in the kit include the plug, plug housing, and 40 wire crimp tail contacts.

Model 7078-MTR Connector Kit (Receptacle)

The Model 7078-MTR contains the parts to assemble and mount one “rack and panel” receptacle. Parts contained in the kit include the receptacle, 40 wire crimp tail contacts, and mounting hardware.

Model 7078-MTC-5 Mass Terminated Cable Assembly

The Model 7078-MTC is a five-foot (1.5 meters), 36-conductor cable terminated with a “rack and panel” plug on both ends. This cable connects to either the ROWS or COLUMNS receptacle on the rear panel of the card. This cable is commonly cut in half to provide two separate cables. The cables can then be used to connect to both the ROWS and COLUMNS receptacles. The unterminated ends of the cables are then connected to instrumentation and DUTs.

Model 7078-MTC-20 Mass Terminated Cable Assembly

This is the same as the Model 7078-MTC-5, except that it is 20-feet (six meters) in length.

CS-570-3 Quick Disconnect Terminal Block

Three-terminal block for row connections. Each terminal will accommodate a single #16 AWG wire or two #22 wires. Mates to matrix board pin terminals.

SECTION 2

Operation

2.1 INTRODUCTION

WARNING

The matrix configuration procedures in this section should only be performed by qualified personnel who recognize shock hazards and are familiar with the safety precautions required to avoid possible injury. Review the safety precautions found at the front of this manual.

This section contains information on aspects of matrix card operation and is arranged as follows:

2.2 Handling Precautions: Details precautions that should be observed when handling the matrix card to ensure that its performance is not degraded due to contamination.

2.3 Card Installation and Removal: Covers the basic procedure for installing and removing the card from the Model 707 Switching Matrix.

2.4 Basic Matrix Configurations: Covers the basic matrix configurations that the card can be configured for; dual 4×12 matrices, a single 4×24 matrix or a single 8×12 matrix.

2.5 Typical Matrix Switching Schemes: Explains some of the basic ways that a matrix can be used to source or measure. Covers single-ended switching, differential (floating) switching, sensing, shielding, and guarding.

2.6 Connections: Discusses the various methods and techniques that can be used to connect DUTs and instrumentation to the matrix card.

2.7 Matrix Expansion: Discusses the various matrix configurations that are possible by using multiple cards. The significance of backplane row jumpers on matrix configurations is also covered here.

2.8 Typical Connection Schemes: Provides examples of external connections for single card, multiple card and multiple mainframe systems.

2.2 HANDLING PRECAUTIONS

To maintain high impedance isolation, care should be taken when handling the matrix card to avoid contamination from such foreign materials as body oils. Such contamination can substantially lower leakage resistances, degrading performance.

To avoid possible contamination, always grasp the card by the handle and side edges. Do not touch the edge connectors of the card and do not touch board surfaces or components. On "rack and panel" connectors and quick-disconnect terminal blocks, do not touch areas adjacent to the electrical contacts.

CAUTION

Do not store the card by leaning it against an object (such as a wall) with its edge connectors in contact with a contaminated surface (such as the floor). The edge connectors will become contaminated, and tapes and solder connections on the PC board may break as the card bends. ALWAYS store the card (in its anti-static bag) in the original shipping carton.

Dirt build-up over a period of time is another possible source of contamination. To avoid this problem, operate the mainframe and matrix card only in a clean environment.

If the card becomes contaminated, it should be thoroughly cleaned as explained in paragraph 4.2.

2.3 CARD INSTALLATION AND REMOVAL

WARNING

To avoid electrical shock that could result in injury or death, ALWAYS remove power from the entire system (Model 707, test instruments, DUT, etc.) and discharge any capacitors before doing any of the following:

1. Installing or removing the matrix card from the mainframe.
2. Connecting or disconnecting cables from the matrix card. The pins of the Model 7078-MTC cable connectors are easily accessible making them extremely hazardous to handle while power is applied.
3. Making internal changes to the card (such as removing or installing jumpers and quick-disconnect terminal blocks).

Cable connections to the matrix card make it awkward to install/remove the card in the mainframe. Thus, it is advisable to install the card and then make cable connections to it. Conversely, cables should be disconnected before removing the card from the mainframe.

Referring to Figure 2-1 and Figure 2-2, perform the following procedure to install the Model 7071-4 matrix card in the Model 707:

1. Turn the Model 707 off.
2. Select a slot in the mainframe and remove the cover-plate. The cover-plate is fastened to the mainframe chassis with two screws. Retain the cover-plate and screws for future use.
3. With the relay side of the matrix card facing towards the fan, feed the card into the slot such that the top

and bottom card edges seat into the the card edge guides of the mainframe. Slide the matrix card approximately 2/3 of the way into the mainframe.

4. If using quick-disconnect terminal blocks to make row connections, perform the following steps. Otherwise, proceed to step 5.

WARNING

Make sure all power is off and stored energy in external circuitry is discharged before making or removing any connections from the matrix card.

- A. There is a cable clamp on the rear panel of the matrix card that serves as a strain relief for terminal block wires. Loosen the two screws of the cable clamp and remove the top half of the clamp.
 - B. Install the wired terminal blocks (see paragraph 2.6.3) on the matrix card. Make sure the pins on the card are properly mated to the terminal blocks.
 - C. Route the wires through the rear panel cable clamp. Make sure there is some slack in the wires between the terminal blocks and the clamp before tightening the clamp.
5. Slide the matrix card all the way into the mainframe and tighten the two spring loaded panel fasteners.

WARNING

The mounting screws must be secured to ensure a proper chassis ground connection between the card and the mainframe. Failure to properly secure this ground connection may result in personal injury or death due to electric shock.

NOTE

If using the terminal blocks, leave enough slack in the external cabling so that the card can slide out far enough to gain access to the connections.

6. To remove the card from the mainframe make sure the Model 707 is off, power is removed from external circuitry, and then reverse the above procedure.

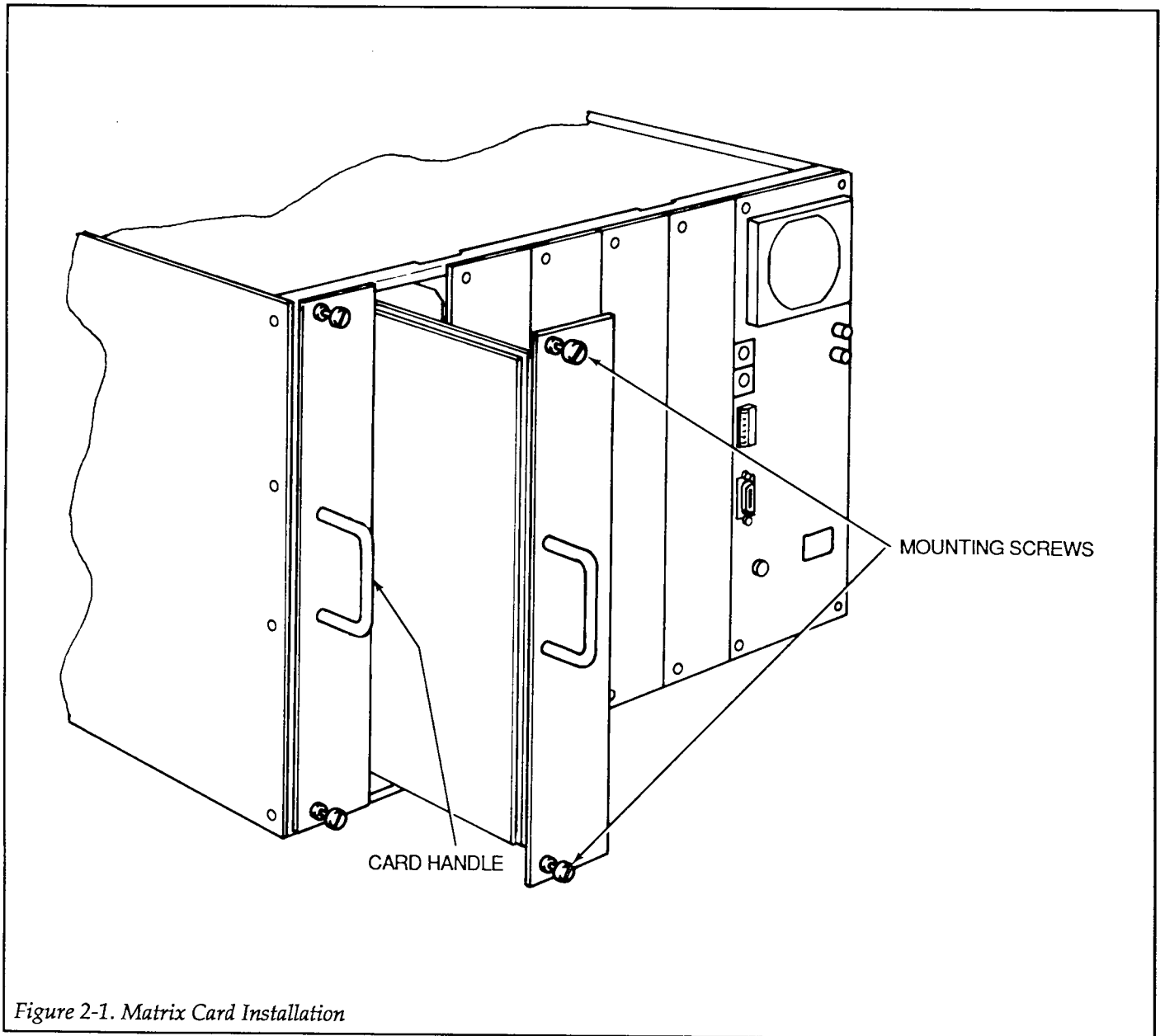

Figure 2-1. Matrix Card Installation

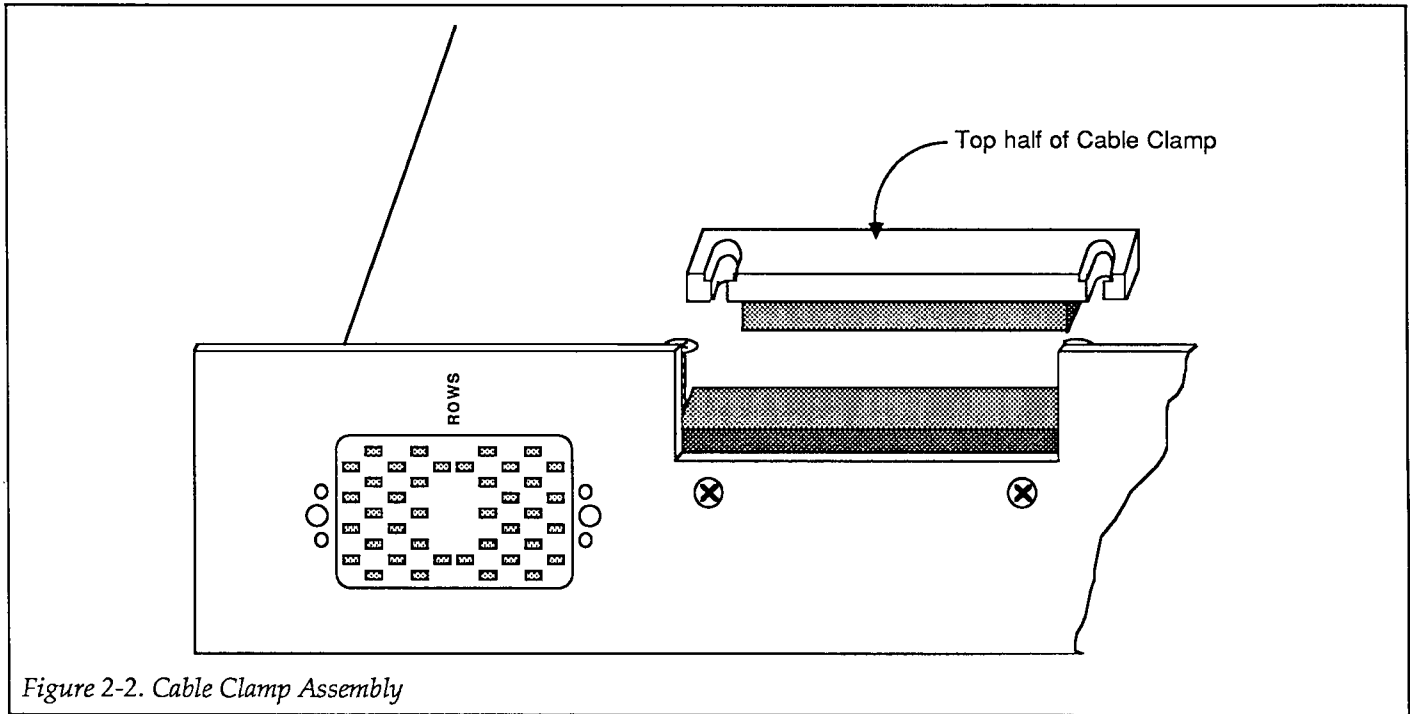

Figure 2-2. Cable Clamp Assembly

2.4 BASIC MATRIX CONFIGURATIONS

A simplified schematic of the Model 7071-4 matrix card is shown in Figure 2-3A. As shipped from the factory, the matrix card is configured as two separate 4×12 matrices. Each of the 96 crosspoints is made up of a three-pole switch. By closing the appropriate crosspoint switch, any matrix row can be connected to any column in the same matrix. The columns of every Model 7071-4 matrix card are labeled 1 through 12 and 1' through 12'. Note that even though there are 24 unique columns in this configuration, the Model 707 recognizes only 12 columns for programming purposes. The crosspoint assignments for the matrix card are provided in Figure 2-3B. For example, to connect row A to column 10, the Model 707 would have to be programmed to close crosspoint A10 (row A, column 10); and to connect row E to column 10' (22nd column), crosspoint E10 would have to be closed. These crosspoint closures assume that the matrix card is installed in slot 1 of the mainframe. The crosspoint assignments in Figure 2-3B are valid regardless of how the card is configured.

The column number assignments for programming the Model 707 are determined by the mainframe slot that the matrix card is installed in. For example, the column number assignments of a matrix card installed in slot 4 of the mainframe are numbered 37 through 48. Column num-

ber assignments for all six mainframe slots are listed in Table 2-1.

Notice in Figure 2-3A that there are backplane jumpers located on the matrix card. With the jumpers installed, the matrix card is connected to the backplane of the Model 707 allowing matrix expansion (see paragraph 2.7). With the jumpers removed (cut), the matrix card is isolated from any other cards installed in the mainframe. The physical location of these jumpers on the board is shown in Figure 2-4.

2.4.1 4×24 Matrix

Figure 2-5 shows how the Model 7071-4 can be configured as a single 4×24 matrix. Row jumper wires are used

Table 2-1. Column Number Assignments

7071-4 Card Location	Matrix Column Numbers
Slot 1	1 through 12
Slot 2	13 through 24
Slot 3	25 through 36
Slot 4	37 through 48
Slot 5	49 through 60
Slot 6	61 through 72

Table 2-2. 4 × 24 Matrix Crosspoint Assignments

Matrix Row*	Matrix Column									
	1	2	3	...	12	1'	2'	3'	...	12'
A (E)	A1	A2	A3	...	A12	E1	E2	E3	...	E12
B (F)	B1	B2	B3	...	B12	F1	F2	F3	...	F12
C (G)	C1	C2	C3	...	C12	G1	G2	G3	...	G12
D (H)	D1	D2	D3	...	D12	H1	H2	H3	...	H12

*In the 4 × 24 matrix configuration, Row A is connected to Row E, Row B is connected to Row F, Row C to Row G and Row D to Row H.

to connect rows A, B, C and D to rows E, F, G and H respectively. A terminal block assembly that has the jumper wires already installed is provided with the Model 7071-4. Simply remove the eight quick-disconnect terminal blocks and install the pre-wired terminal block assembly (see paragraph 2.6.3). In a multiple card system where backplane jumpers are left installed, row jumpers are only required at one card. Rows can also be jumpered externally as shown in Figure 2-22.

Cutting the backplane jumpers will isolate the 4 × 24 matrix from any other card installed in the mainframe.

Crosspoint assignments for programming the Model 707 do not change even though the matrix configuration of the card has changed (see Figure 2-3B). For example, to connect row A to the 24th (12') column of the 4 × 24 matrix (see the equivalent circuit in Figure 2-5), the Model 707 would have to be programmed to close crosspoint E12 (assuming the card is installed in slot 1 of the mainframe). Table 2-2 provides the crosspoint assignments for a Model 7071-4 configured as a 4 × 24 matrix installed in slot 1 of the mainframe. Table 2-1 provides the column number assignments for the other mainframe slots.

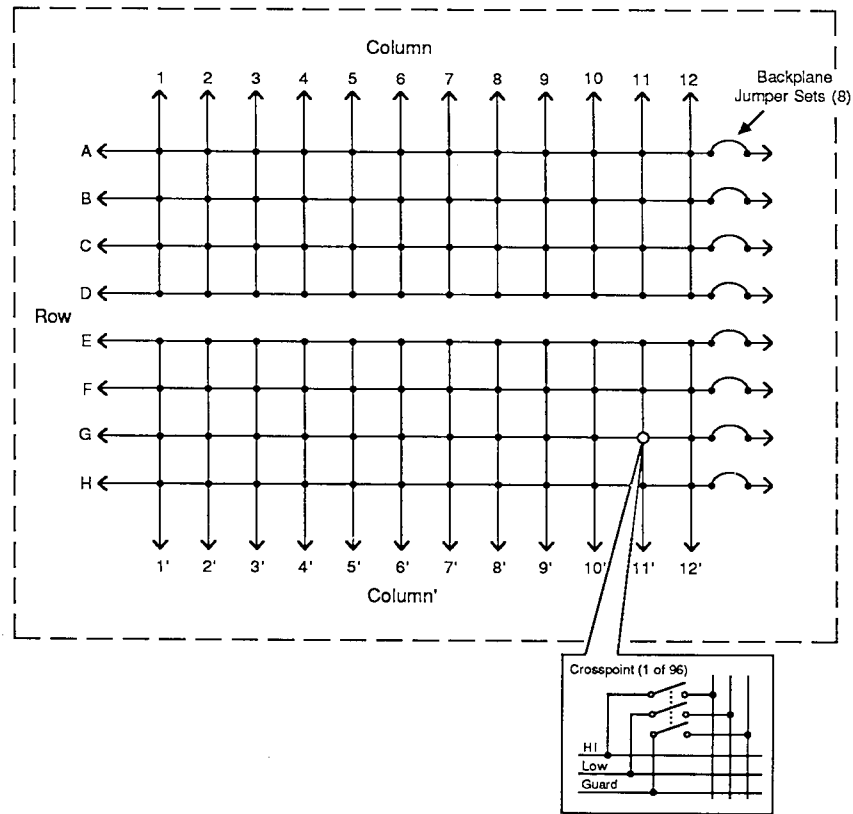

A. Simplified Schematic

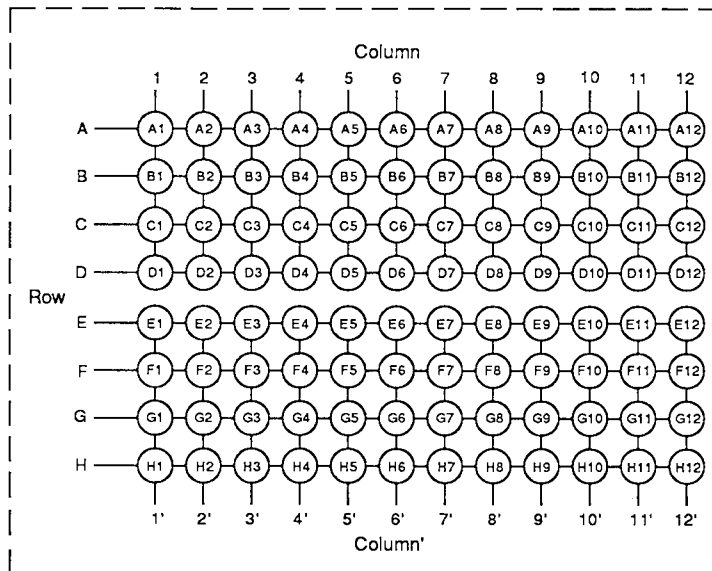

Note : 7071-4 Installed in slot one of Model 707 Mainframe

B. Crosspoint Assignments

Figure 2-3. Model 7071-4

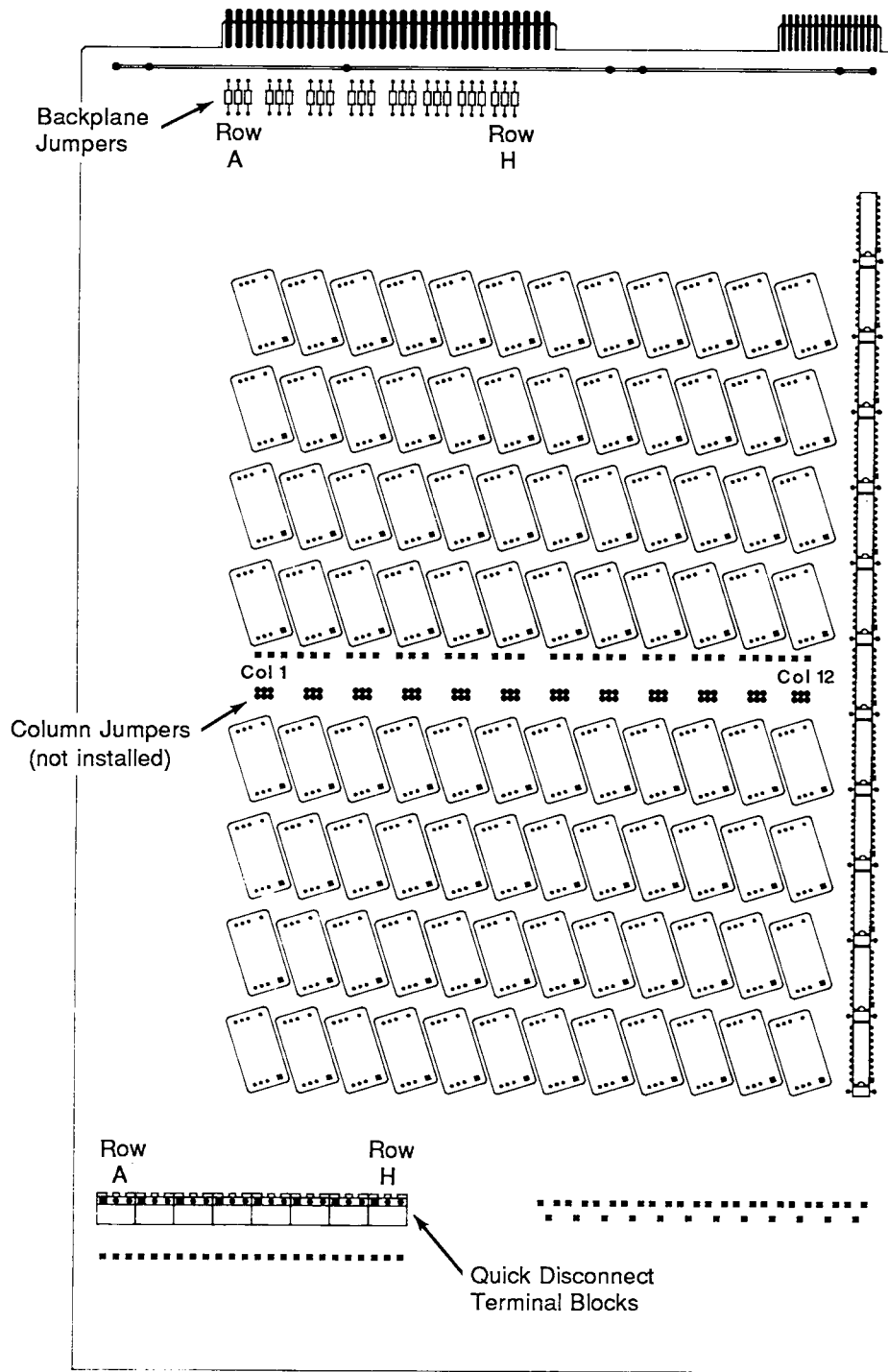

Note : Contact identification of the rows and columns receptacles is provided in Figure 4-10 in the service section.

Figure 2-4. Simplified Component Layout

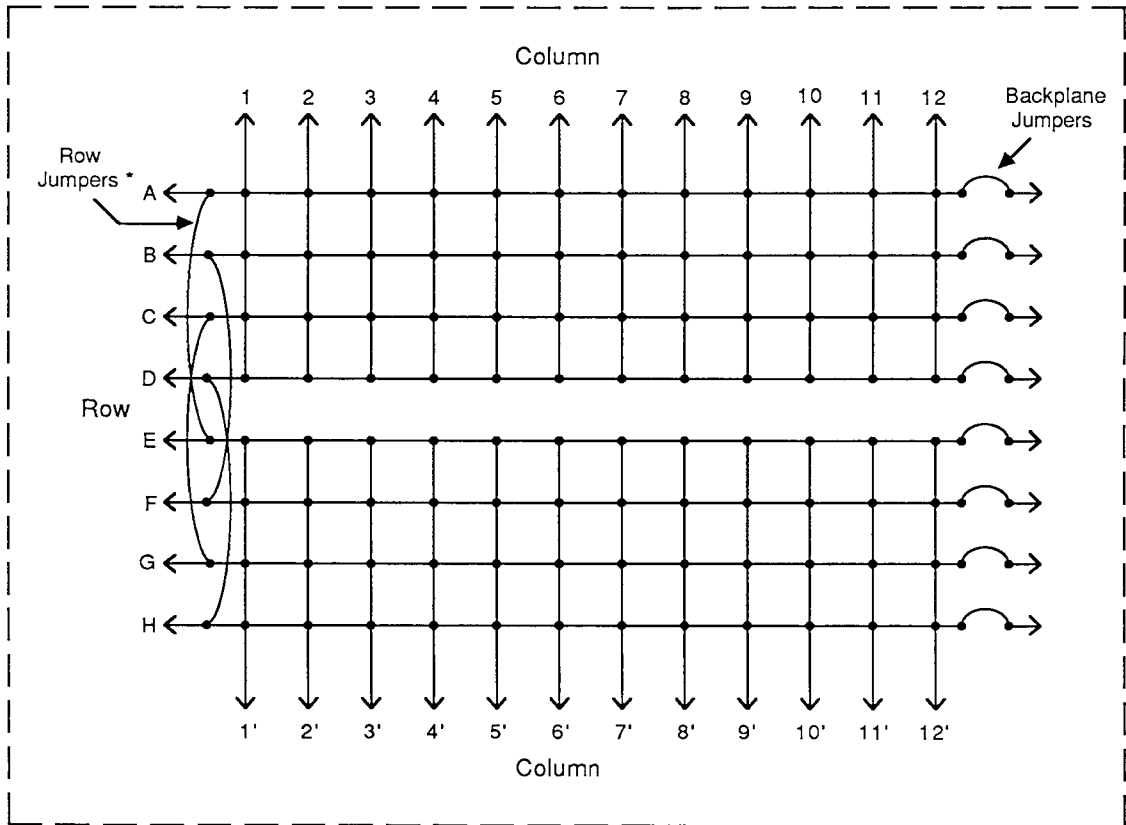

* Supplied terminal block assembly pre-wired with jumpers (see Fig. 2-20) for a 4X24 Matrix Configuration

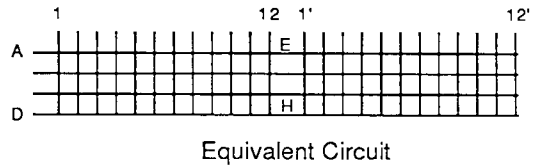

Figure 2-5. Model 7071-4 Configured as 4 x 24 Matrix

2.4 .2 8 × 12 Matrix

Figure 2-6 shows that the Model 7071-4 can be configured as a standard 8 × 12 matrix by installing the column jumpers. The location of the column jumpers on the PC-board is shown in Figure 2-4. As shipped from the factory, the 12 column jumpers sets are not installed. Install-

ing the 12 jumpers sets, as shown in Figure 2-7, configures the Model 7071-4 as an 8 × 12 matrix.

With the Model 7071-4 backplane jumpers installed, the 8 × 12 matrix is connected to the backplane of the Model 707 allowing matrix expansion (see paragraph 2.7). With

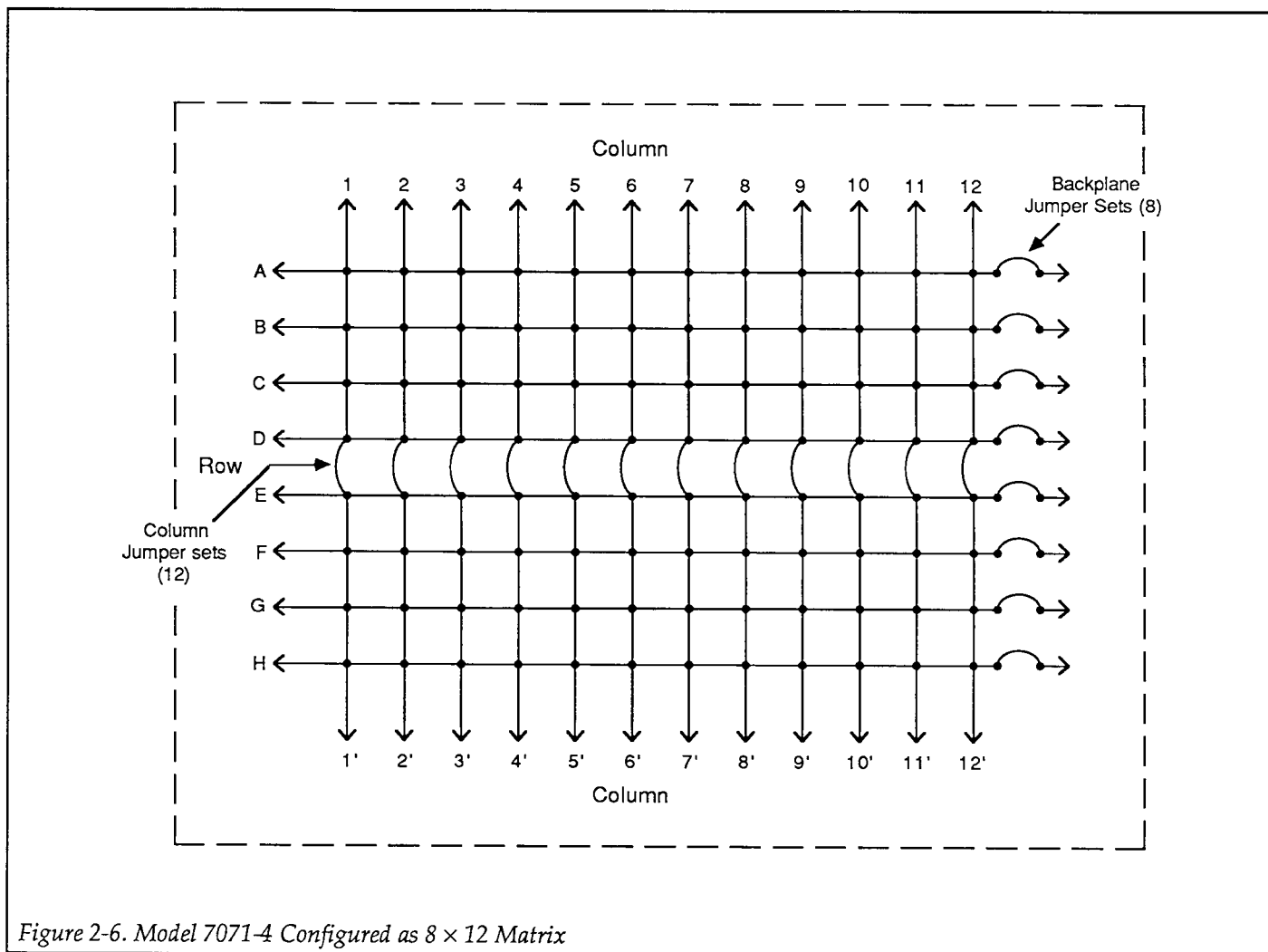

Figure 2-6. Model 7071-4 Configured as 8 × 12 Matrix

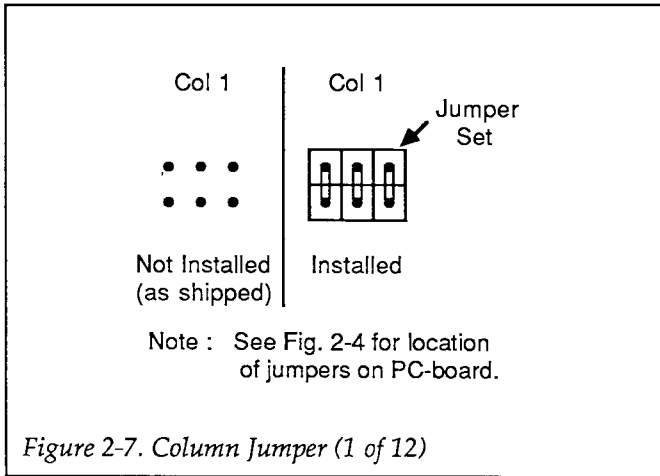

Figure 2-7. Column Jumper (1 of 12)

2.5 TYPICAL MATRIX SWITCHING SCHEMES

2.5.1 Single-ended Switching

The following paragraphs describe some basic switching schemes that are possible with a three-pole switching matrix.

In the single-ended switching configuration, the source or measure instrument is connected to the DUT through a single pathway as shown in Figure 2-8. Note that in the illustration that the matrix card guard (G) is used as a shield. The matrix card guard is used as the shield because its PC board trace physically surrounds the high (H) and low (L) traces .

2.5.2 Differential Switching

the backplane jumpers cut, the 8 × 12 matrix will be isolated from any other card installed in the mainframe.

The differential or floating switching configuration is shown in Figure 2-9. The advantage of using this con-

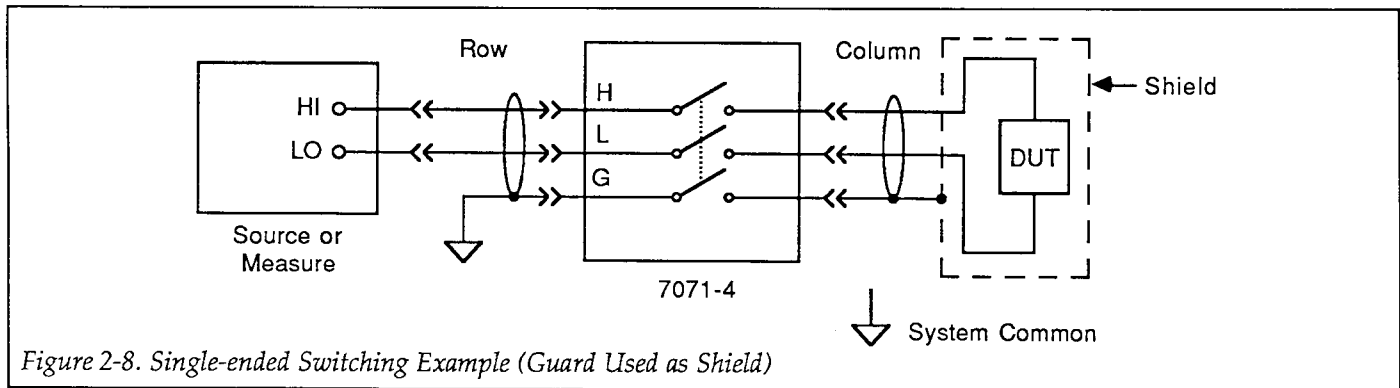

Figure 2-8. Single-ended Switching Example (Guard Used as Shield)

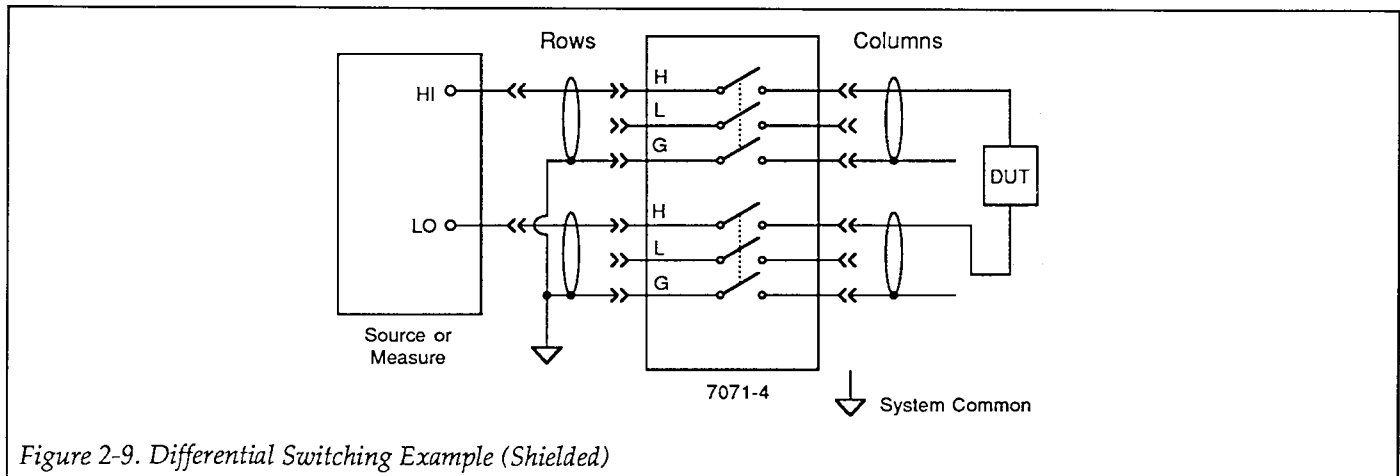

Figure 2-9. Differential Switching Example (Shielded)

figuration is that the terminals of the source or measure instrument are not confined to the same matrix crosspoint. Each terminal of the instrument can be connected to any matrix crosspoint. Again, the guard terminals of the matrix card are used as a shield.

2.5.3 Guarding

Figure 2-10 shows how the matrix card can be used with a driven guard. Since the driven guard is at virtually the same potential as signal high, protection from possible hazardous voltages (up to 200V) must be provided. Many instruments have the capability of configuring their input or output such that a driven guard is placed on the inner shield of a triax connector. The outer shield, connected to system common, provides protection from the guard voltage. When making connections from the matrix card to the DUT, a safety shield may be required, depending on the type of connectors used.

2.5.4 Sensing

Figure 2-11 shows how the matrix card can be configured to use instruments that have sensing capability. The main advantage of using sensing is to cancel the effects of matrix card path resistance ($\approx 1.5\Omega$) and the resistance of external cabling. Whenever path resistance is a consideration, sensing should be used. In the illustration, matrix card guard is again used as a shield. In a system where a driven guard is required, matrix card guard (G) can be connected to the guard potential. However, make

sure that the guard is adequately insulated to prevent possible electrical shock, or use quadrax cables using the outer shield as a grounded safety shield.

2.6 CONNECTION METHODS

CAUTION

To prevent damage (not covered by the warranty) and a possible safety hazard, do not exceed the maximum allowable limits of the Model 7071-4. Maximum signal levels are listed in the specifications located at the front of the manual

As shipped, all rows and columns of the Model 7071-4 matrix card are connected to the three "rack and panel" receptacles mounted on the rear panel of the matrix card. One receptacle is provided for row connections and two receptacles are provided for column connections. The lower columns receptacle is for rows A through D, while the upper columns receptacle is for rows E through H. These receptacles will mate with either the optional mass terminated cable (Model 7078-MTC) or the plug provided in the optional connector kit (Model 7078-KIT). As an alternative, row connections can instead be made directly to quick-disconnect terminal blocks.

The following paragraphs explain the three connection methods. Keep in mind that based on convenience and performance considerations, it may be best to use a combination of connection methods. For example, it may be most convenient to connect instrumentation to the matrix rows using quick-disconnect terminal blocks rather

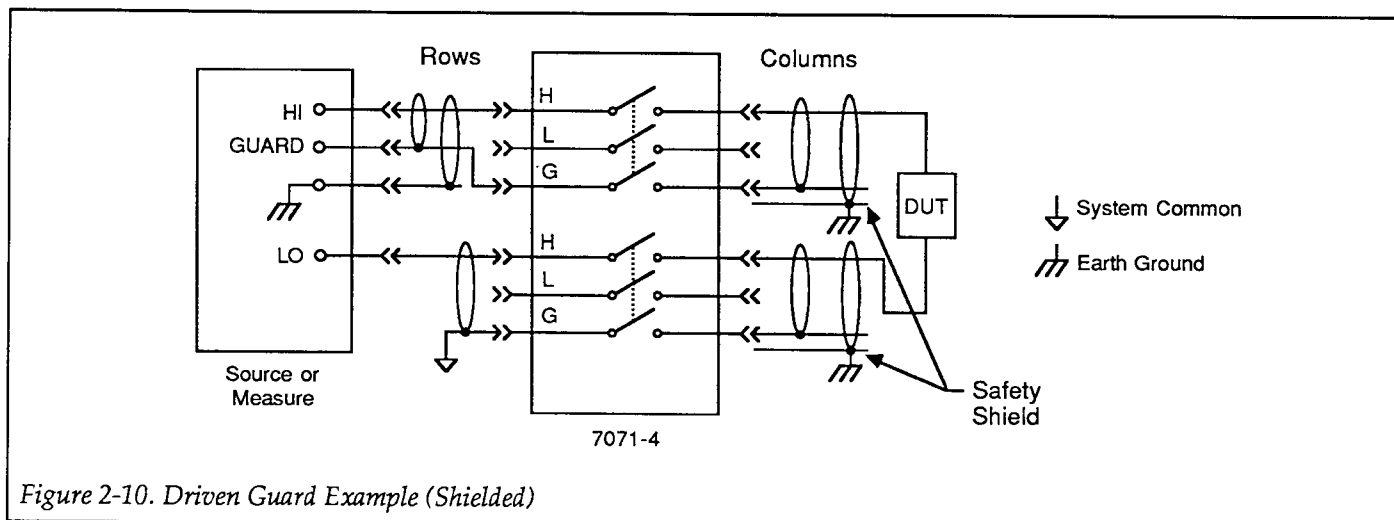

Figure 2-10. Driven Guard Example (Shielded)

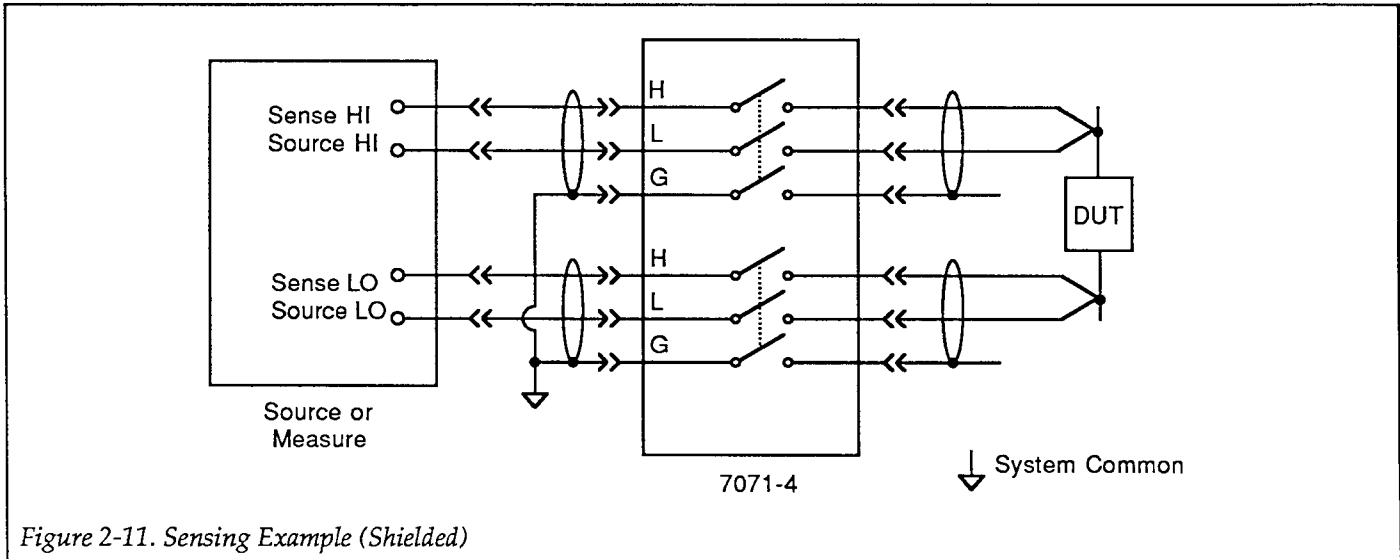

Figure 2-11. Sensing Example (Shielded)

than using the ROWS receptacle. Some advantages of each of the connection methods are as follows:

Mass Terminated Cable Method (Model 7078-MTC) — Probably the most convenient method to make connections to the matrix card. By cutting the cable in half (or wherever appropriate), two separate cables, un-terminated at one end, will result. These cables can then be hard-wired to DUTs or to a user's test fixture. The plug on each cable will then connect to the ROWS or COLUMNS receptacle on the card. Using the whole cable (both plugs intact) makes it most convenient to connect the matrix card to a test fixture that uses a "rack and panel" receptacle.

Connector Kit (Model 7078-KIT) — This kit contains a plug that mates to the "rack and panel" receptacles. This plug is used to custom build a cable assembly that meets the user's requirements. This allows the user to select the cable and wire only the rows and columns needed for a particular application. This can result in a cable assembly that is much smaller in diameter than the Model 7078-MTC.

Each conductor of the 20-foot Model 7078-MTC-20 cable has 480mΩ of resistance. Each conductor of the 5-foot Model 7078-MTC-5 cable has 120mΩ of resistance. In an application where path resistance is critical, this path resistance may be too high. Thus, another advantage of the connector kit is to build shorter, low resistance cables. An alternative to building a cable from scratch is to cut the Model 7078-MTC cable at a length that is suitable and then attach the plug to it.

Direct Connection Method (Rows Only) — This method makes row connections at the quick-disconnect terminal blocks bypassing the "rack and panel" receptacle. The main advantage of this method is that it is convenient to connect unterminated or individual cables from instrumentation to the terminal blocks.

WARNING

To avoid electrical shock that could result in injury or death, ALWAYS remove power from the entire system (Model 707, test instruments, DUT, etc.) and discharge any capacitors before doing any of the following:

1. Installing or removing the matrix card from the mainframe.
2. Connecting or disconnecting cables from the matrix card. The pins of the Model 7078-MTC cable connectors are easily accessible making them extremely hazardous to handle while power is applied.
3. Making internal changes to the card (such as removing or installing jumpers and quick-disconnect terminal blocks).

CAUTION

Contamination will degrade the performance of the matrix card. To avoid contamination, always grasp the card by the handle and side edges. Do not touch the edge connectors of the card, and do not touch the board surfaces or components. On "rack and panel" connectors and quick-disconnect ter-

minal blocks, do not touch areas adjacent to the electrical contacts.

tional receptacles can then be hard-wired to other connectors or wired directly to instrumentation and DUTs.

2.6 .1 Connections Using Mass Terminated Cable (Model 7078-MTC)

Use the following procedure to connect the Model 7078-MTC cable to the matrix card:

The Model 7078-MTC-5 is a 1.5 meter (five feet), 36 conductor cable terminated with a "rack and panel" plug on each end. The Model 7078-MTC-20 is the same except that it is six meters (20 feet) in length. These cables are used to connect the ROWS or COLUMNS receptacles on the rear panel of the card to external instrumentation and test circuits. Figure 2-12 shows how three cables can be used to connect rows and columns of the matrix card to additional "rack and panel" receptacles. These addi-

WARNING

To avoid electrical shock that could result in injury or death, ALWAYS remove power from the entire system (Model 707, test instruments, DUT, etc.) and discharge any capacitors before connecting or disconnecting cables from the matrix card. The pins of the Model 7078-MTC cable connectors are easily accessible making them extremely hazardous to handle while power is applied.

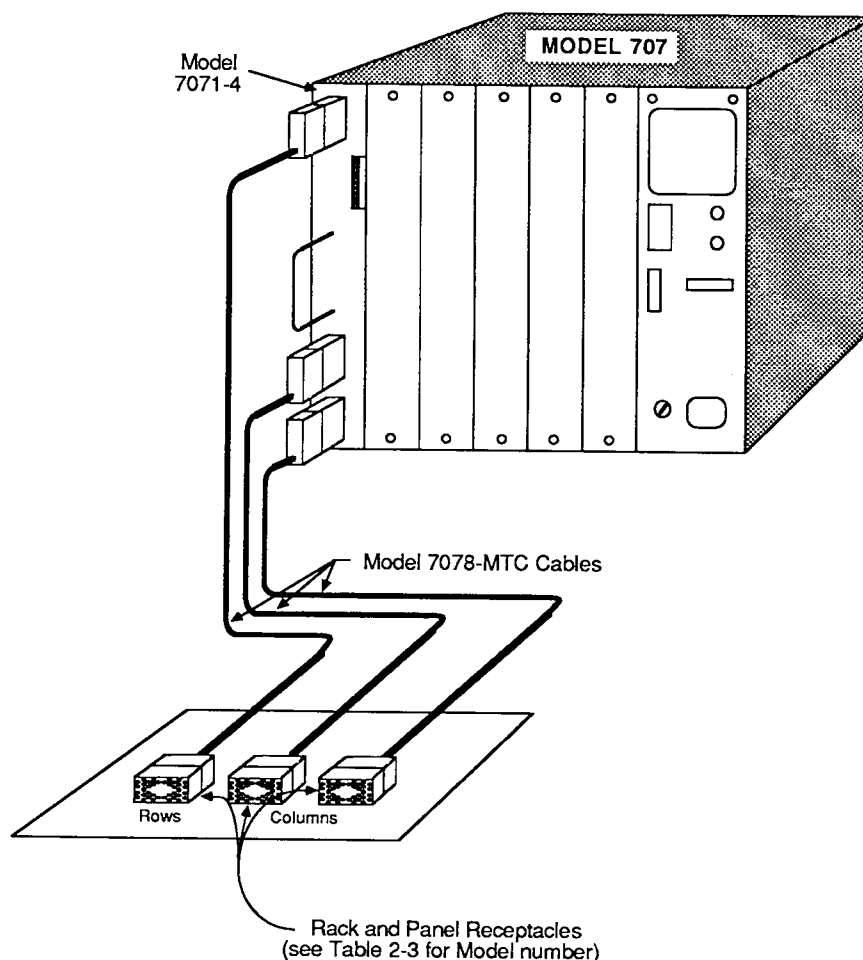

Figure 2-12. Connections Using Three Model 7078-MTC Cables

1. Install the matrix card in the Model 707 mainframe as explained in paragraph 2.3 .
2. Place the plug of the cable on the appropriate "rack and panel" receptacle such that the large diameter keying pin of the plug aligns with the large keyway of the receptacle (Figure 2-13).

3. Using a slotted screwdriver, turn the locking screw clockwise until the plug is fully mated to the receptacle.

The same basic procedure applies for connecting the cable plug to a test fixture receptacle

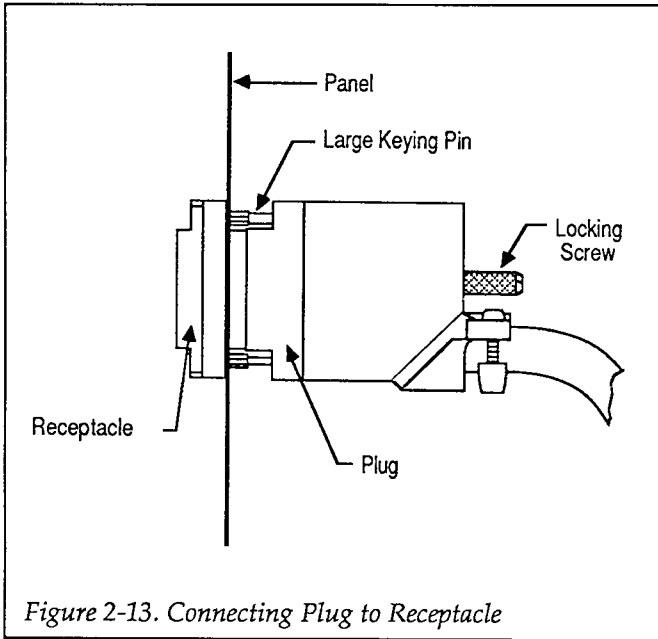

Figure 2-13. Connecting Plug to Receptacle

Receptacle Wiring

"Rack and panel" receptacles (Model 7078-MTR) along with recommended installation tools are available from Keithley (see Table 2-3). Perform the following steps to wire a "rack and panel" receptacle.

1. Remove 1/8" of insulation from the wires that are to be connected to the receptacle.
2. Using the Model 7078-HCT crimping tool, connect a wire crimp tail to each of the wires.
3. Figure 2-14 provides contact identification for ROWS and COLUMNS receptacles. Using this illustration as a guide, insert the wire crimp tails into the receptacle. Use the Model 7078-CIT insertion tool to push each wire crimp tail completely into the receptacle.

Table 2-3. Model 7071-4 Available Accessories

Model or Part	Description
Model 7078-CIT: Insertion and Extraction Tools	Used to install/remove wire crimp tails into/from "rack and panel" plugs and receptacles.
Model 7078-HCT: Hand Crimping Tool	Used to connect wire crimp tails to #18 to #26 gage wire.
Model 7078-KIT: Connection Kit (Plug)	Contains one "rack and panel" plug, housing and 40 wire crimp tails. Mates to either Rows or Columns receptacle on the Model 7071-4. Also, mates to the Model 7078-MTR
Model 7078-MTR: Connector Kit (Receptacle)	Contains one "rack and panel" receptacle, 40 wire crimp rails, and mounting hardware. Mates to the Model 7078-MTC cables. Also, mates to Model 7078-KIT plug.
Model 7078-MTC-20: Mass Terminated Cable	6 meter (20 ft.), 36 conductor cable terminated with "rack and panel" plugs. Mates to "rack and panel" receptacles.
Model 7078-MTC-5: Mass Terminated Cable	Same as Model 7078-MTC-20, except 1.5 meters (5 ft.) in length.
CS-570-3: Quick Disconnect Terminal Block	3-terminal block accommodates up to 16 AWG wires. Mates to matrix card board pin terminals.

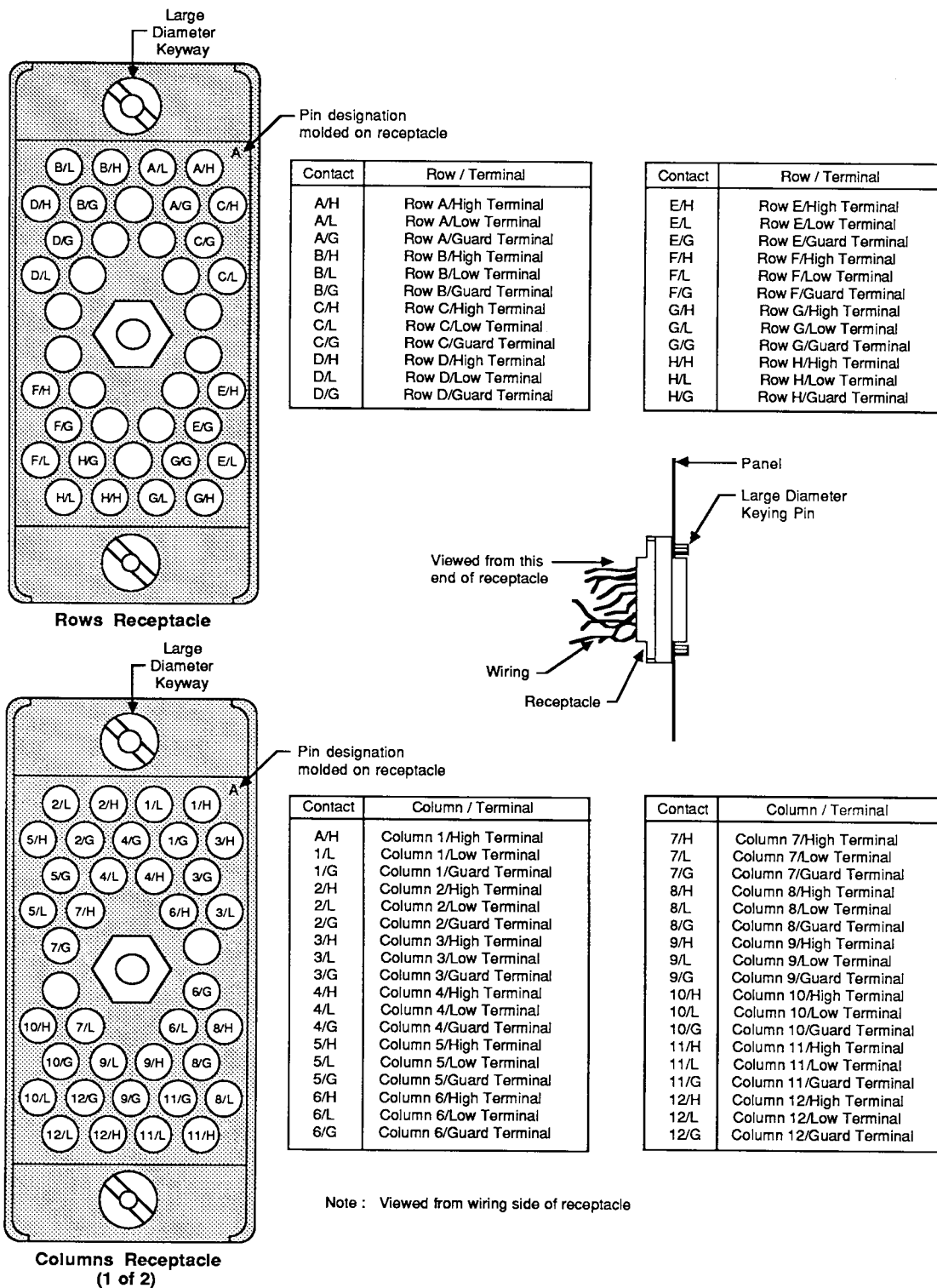

Figure 2-14. Receptacle Contact Assignments

Modified Mass Terminated Cable

Another way to use the Model 7078-MTC cable is to cut the cable and add appropriate user termination. Cutting the Model 7078-MTC-5 cable in half will provide two 2.5-foot cables. Cutting the Model 7078-MTC-20 cable in half will provide two 10-foot cables. Each cable can then be mated to the ROWS or COLUMNS receptacle (see Figure 2-15). The wire end of each cable can then be wired to another connector or wired directly to instrumentation or DUTs. The cable contains 12 bundles of wires each of which corresponds to a row or column. Each bundle contains three wires; a bare wire (guard) and two insulated wires that have a unique color combination for identification purposes. Table 2-4 provides the color combinations for each bundle. For example, with the cable connected to the ROWS receptacle of the matrix card, Row E can be identified by locating the bundle that has a red insulated wire (H) and a blue insulated wire (L). The bare wire in the bundle is guard (G).

NOTE

If another "rack and panel" plug is to be attached to the unterminated end of the cable, refer to the connection procedure in paragraph 2.6.2.

The outer side of the foil shield is insulated while the inner wrapping is conductive (guard). When the cable is cut, it is likely that the conductive side of the bundle wrapping will become exposed. Thus, each bundle, as well as each bare wire, should be insulated as follows:

1. Place a length of Teflon® tubing over each bare wire.
2. Place a length of shrink tubing over the bundle such that the frayed end of the bundle wrapping and part of the Teflon® tubing are covered.
3. Heat the shrink tubing.

Table 2-4. Model 7078-MTC Wire Identification

Wire Set	Terminal*	Insulation Color	Wire Set	Terminal*	Insulation Color
COL 1 or ROW A	H L G	Black Blue Bare Wire	COL 7	H L G	Red White Bare Wire
COL 2 or ROW B	H L G	Red Brown Bare Wire	COL 8 or ROW E	H L G	Black Brown Bare Wire
COL 3 or ROW C	H L G	Black Red Bare Wire	COL 9	H L G	Black White Bare Wire
COL 4	H L G	Black Green Bare Wire	COL 10 or ROW F	H L G	Red Blue Bare Wire
COL 5 or ROW D	H L G	Red Yellow Bare Wire	COL 11 or ROW G	H L G	Black Orange Bare Wire
COL 6	H L G	Black Yellow Bare Wire	COL 12 or ROW H	H L G	Red Green Bare Wire

*H = High
L = Low
G = Guard

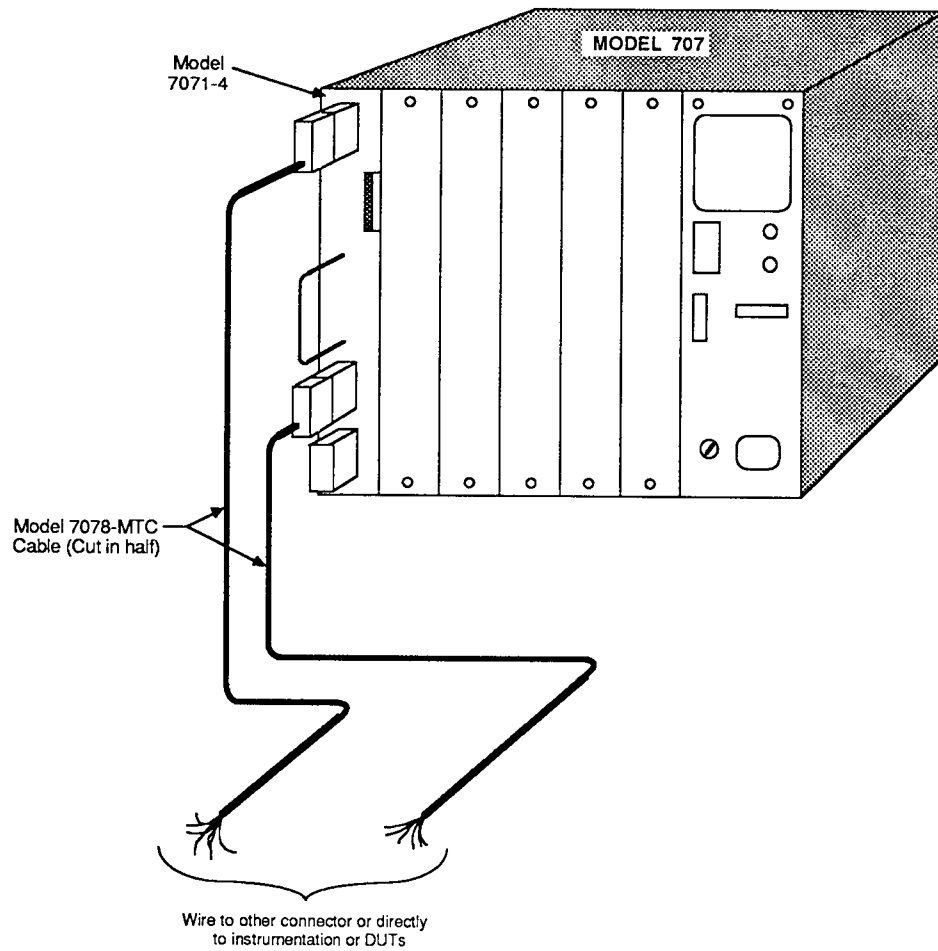

Figure 2-15. Connections Using One Model 7078-MTC Cable Cut in Half

2.6 .2 Connections Using Connector Kit (Model 7078-KIT)

The Model 7078-KIT contains the parts of one "rack and panel" plug. This kit allows the user to build a cable that will mate to the "rack and panel" receptacles of the matrix card.

NOTE

The following procedure shows how to properly connect a 36 conductor cable to a "rack and panel" plug. The cable used in the procedure is the same one used in the Model 7078-MTC and is available from Belden (P/N 9734). Modify the procedure accordingly if using a different cable or individual wires, and use Figure 2-19 as a guide instead of Figure 2-17.

Perform the following steps to connect the 36 conductor Belden cable to the Model 7078-KIT plug:

1. Feed one end of the cable through the plug housing. Slide the housing far enough down the cable to set it out of the way.

NOTE

Refer to Figure 2-16 for steps 2 through 5.

2. Using a sharp knife, remove 1-3/4" of insulation from the end of the cable. Be careful not to cut into the insulated shield of any of the internal wire bundles.

3. Remove 1" of insulated shielding from each of the 12 bundles of wires.
4. Using Teflon® tubing, insulate the bare guard wire of each bundle so that they do not short out to each other.
5. Remove 1/8" of insulation from the 24 insulated wires.
6. Using the Model 7078-HCT crimping tool, connect a wire crimp tail to each of the 36 wires. The wires are #24 gage so be sure to use the slot labeled "22 - 26" on the tool.

NOTE

Figure 2-17 shows where the wires of each bundle belong. The wires in each bundle have a unique color combination that is different from the color combination of any other bundle.

7. Insulate the locking screw of the plug with shrink tubing as shown in Figure 2-18.
8. Orient the cable to the plug as shown in Figure 2-18, and using Figure 2-17 as a guide, insert the wire crimp tails into the plug. Use the Model 7078-CIT insertion tool to push each wire crimp tail completely into the plug.
9. Slide the housing over the plug and install the four screws that secure the housing to the plug.
10. Tighten the two cable clamp screws on the housing.

The "rack and panel" plug will mate to the receptacles on the matrix card in the same manner as the Model 7078-MTC cable. The other end of the cable can be wired directly to instrumentation or DUTs, or to another connector.

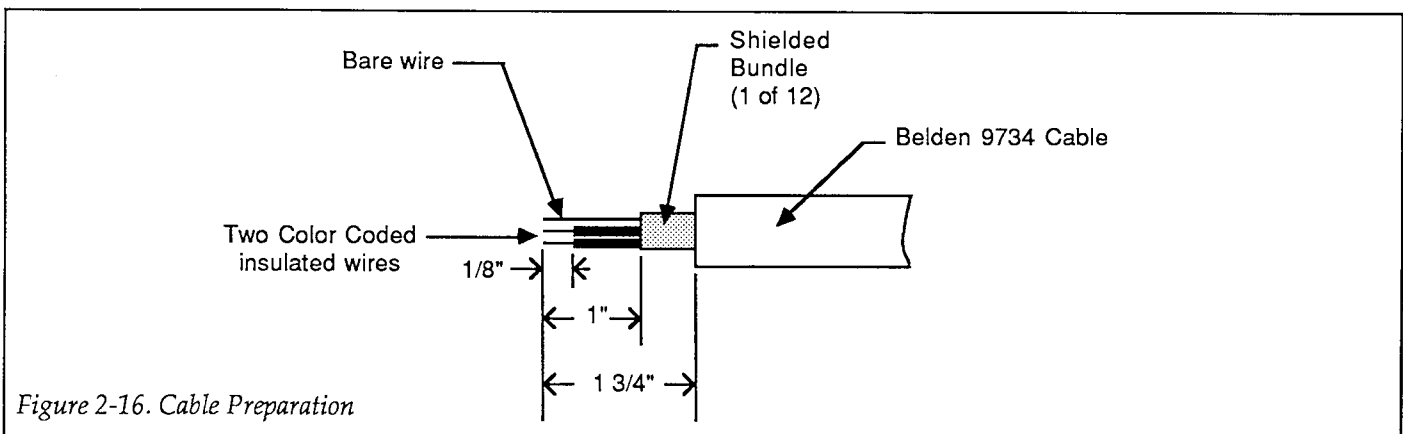

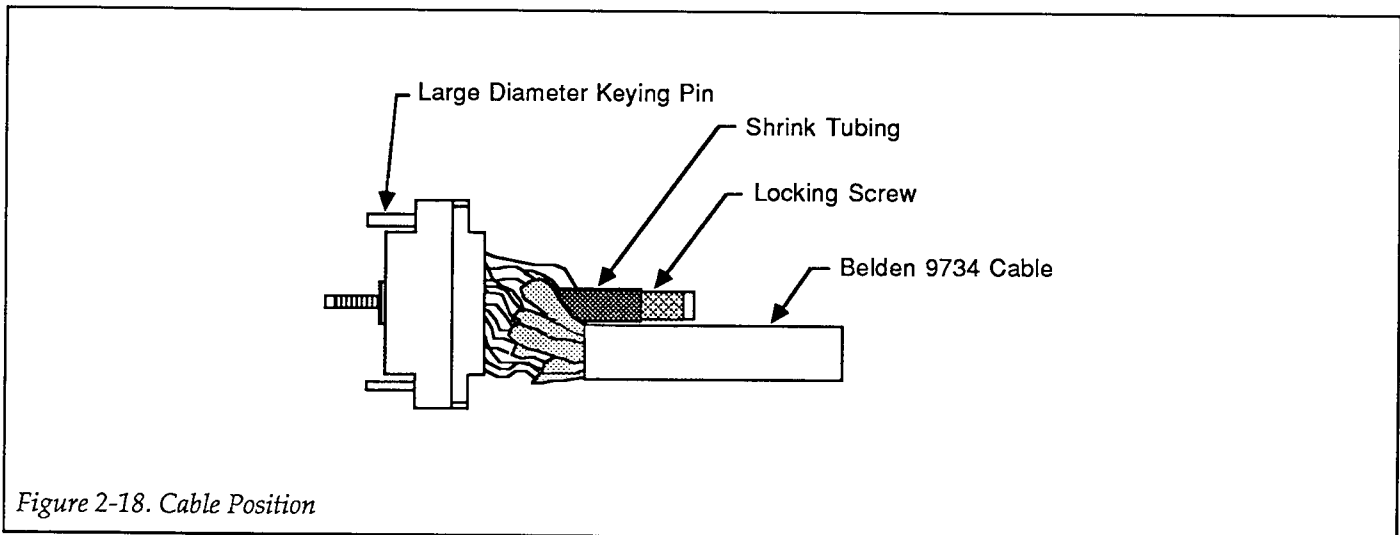
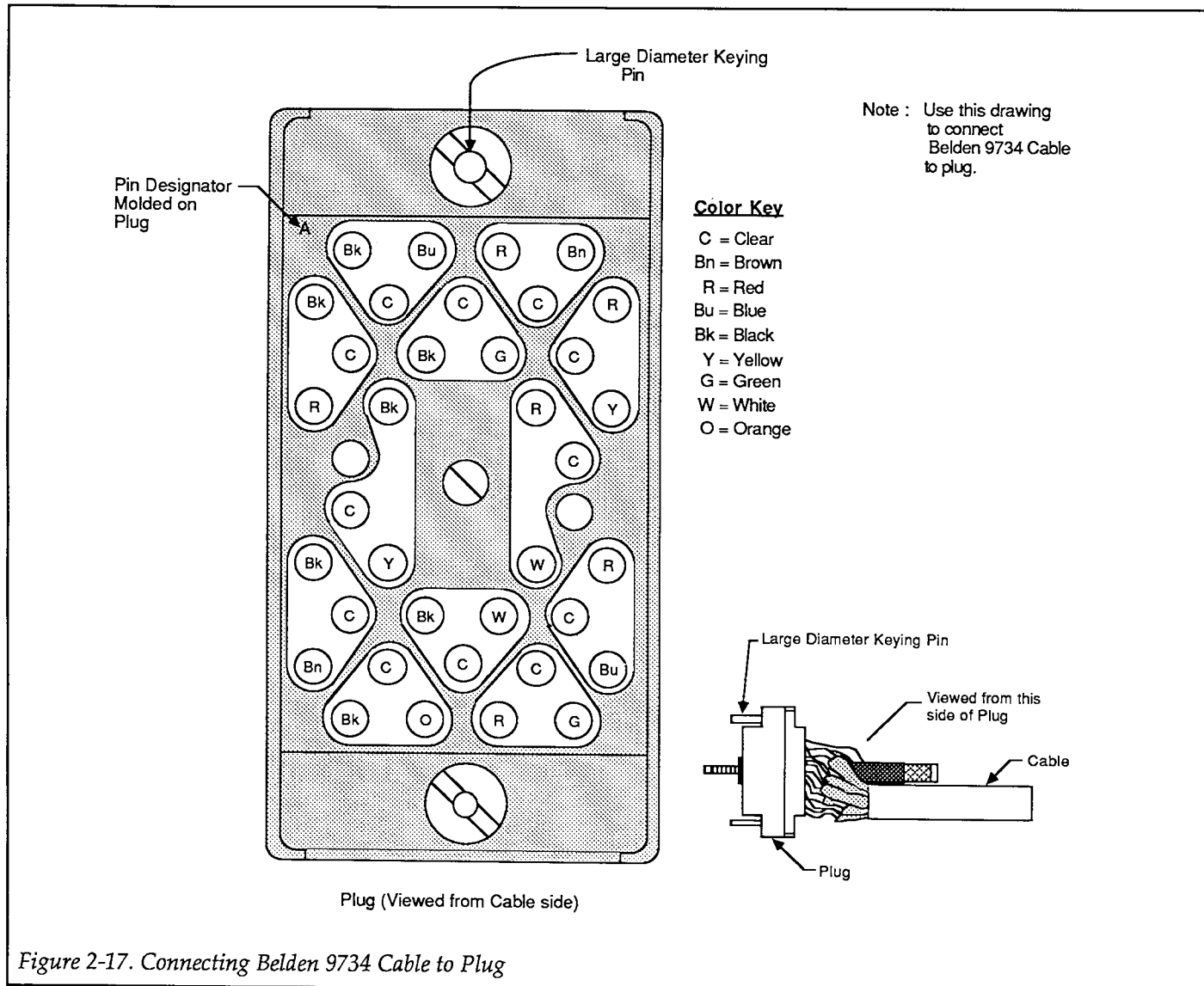

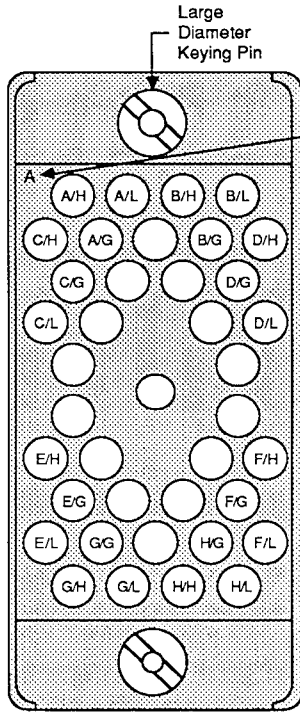

Rows Plug

Note : Use this drawing to connect custom cable to plug.

Contact	Row / Terminal
A/H	Row A/High Terminal
A/L	Row A/Low Terminal
A/G	Row A/Guard Terminal
B/H	Row B/High Terminal
B/L	Row B/Low Terminal
B/G	Row B/Guard Terminal
C/H	Row C/High Terminal
C/L	Row C/Low Terminal
C/G	Row C/Guard Terminal
D/H	Row D/High Terminal
D/L	Row D/Low Terminal
D/G	Row D/Guard Terminal

Contact	Row / Terminal
E/H	Row E/High Terminal
E/L	Row E/Low Terminal
E/G	Row E/Guard Terminal
F/H	Row F/High Terminal
F/L	Row F/Low Terminal
F/G	Row F/Guard Terminal
G/H	Row G/High Terminal
G/L	Row G/Low Terminal
G/G	Row G/Guard Terminal
H/H	Row H/High Terminal
H/L	Row H/Low Terminal
H/G	Row H/Guard Terminal

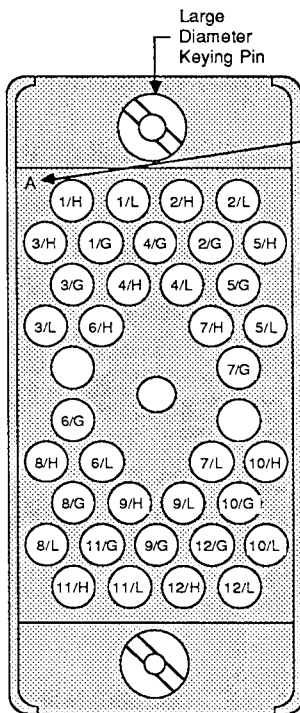
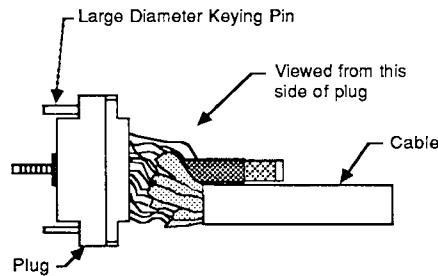

Columns Plug

Contact	Column / Terminal
1/H	Column 1/High Terminal
1/L	Column 1/Low Terminal
1/G	Column 1/Guard Terminal
2/H	Column 2/High Terminal
2/L	Column 2/Low Terminal
2/G	Column 2/Guard Terminal
3/H	Column 3/High Terminal
3/L	Column 3/Low Terminal
3/G	Column 3/Guard Terminal
4/H	Column 4/High Terminal
4/L	Column 4/Low Terminal
4/G	Column 4/Guard Terminal
5/H	Column 5/High Terminal
5/L	Column 5/Low Terminal
5/G	Column 5/Guard Terminal
6/H	Column 6/High Terminal
6/L	Column 6/Low Terminal
6/G	Column 6/Guard Terminal

Contact	Column / Terminal
7/H	Column 7/High Terminal
7/L	Column 7/Low Terminal
7/G	Column 7/Guard Terminal
8/H	Column 8/High Terminal
8/L	Column 8/Low Terminal
8/G	Column 8/Guard Terminal
9/H	Column 9/High Terminal
9/L	Column 9/Low Terminal
9/G	Column 9/Guard Terminal
10/H	Column 10/High Terminal
10/L	Column 10/Low Terminal
10/G	Column 10/Guard Terminal
11/H	Column 11/High Terminal
11/L	Column 11/Low Terminal
11/G	Column 11/Guard Terminal
12/H	Column 12/High Terminal
12/L	Column 12/Low Terminal
12/G	Column 12/Guard Terminal

Note : Viewed from cable side of plug.

Figure 2-19. Plug Contact Assignments

2.6 .3 Direct Connections (Rows)

With this method, row connections are made directly to quick-disconnect terminal blocks. The "rack and panel" receptacle is not used. Additional terminal blocks are available from Keithley (see Table 2-3). If the card is going to be configured as a 4 × 24 matrix, use the pre-wired terminal block assembly.

NOTE

For optimum performance, use a low noise, shielded cable that has excellent insulation qualities (such as Teflon® or polystyrene).

Perform the following steps to wire the matrix card:

WARNING

To avoid electrical shock that could result in injury or death, ALWAYS remove power from test circuits and instrumentation and discharge any capacitors before making or removing connections from the matrix card.

1. If using the standard 3-terminal quick-disconnect blocks, carefully pull the ones that are going to be used off of the PC board.
2. Using a screwdriver, connect the circuitry to the terminal blocks. Figure 2-20 shows how a triaxial cable may be connected. Each screw terminal will accept a single #16 AWG wire or two #22 wires.

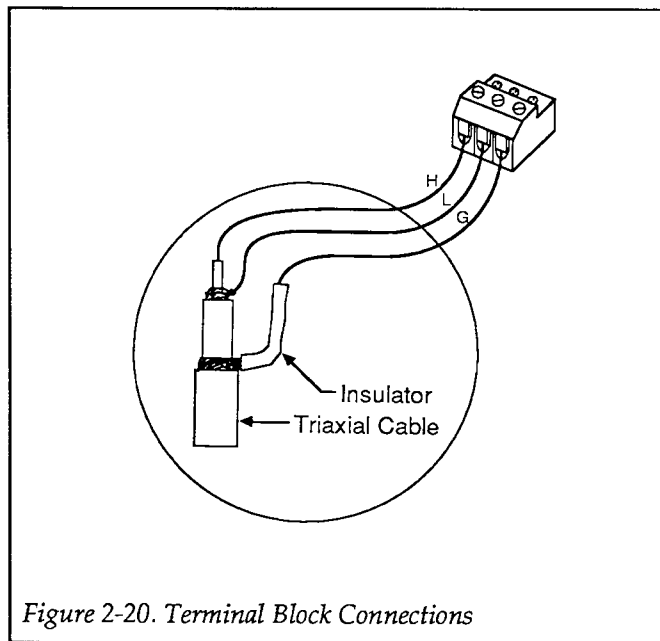

Figure 2-20. Terminal Block Connections

NOTE

The pre-wired terminal block assembly uses #22 gage jumper wires. Thus, each terminal of this connector assembly will accommodate one additional #22 gage wire (see Figure 2-21).

3. The terminal blocks should be connected to the matrix card during installation of the card into the mainframe. The procedure to do this is contained in paragraph 2.3 .

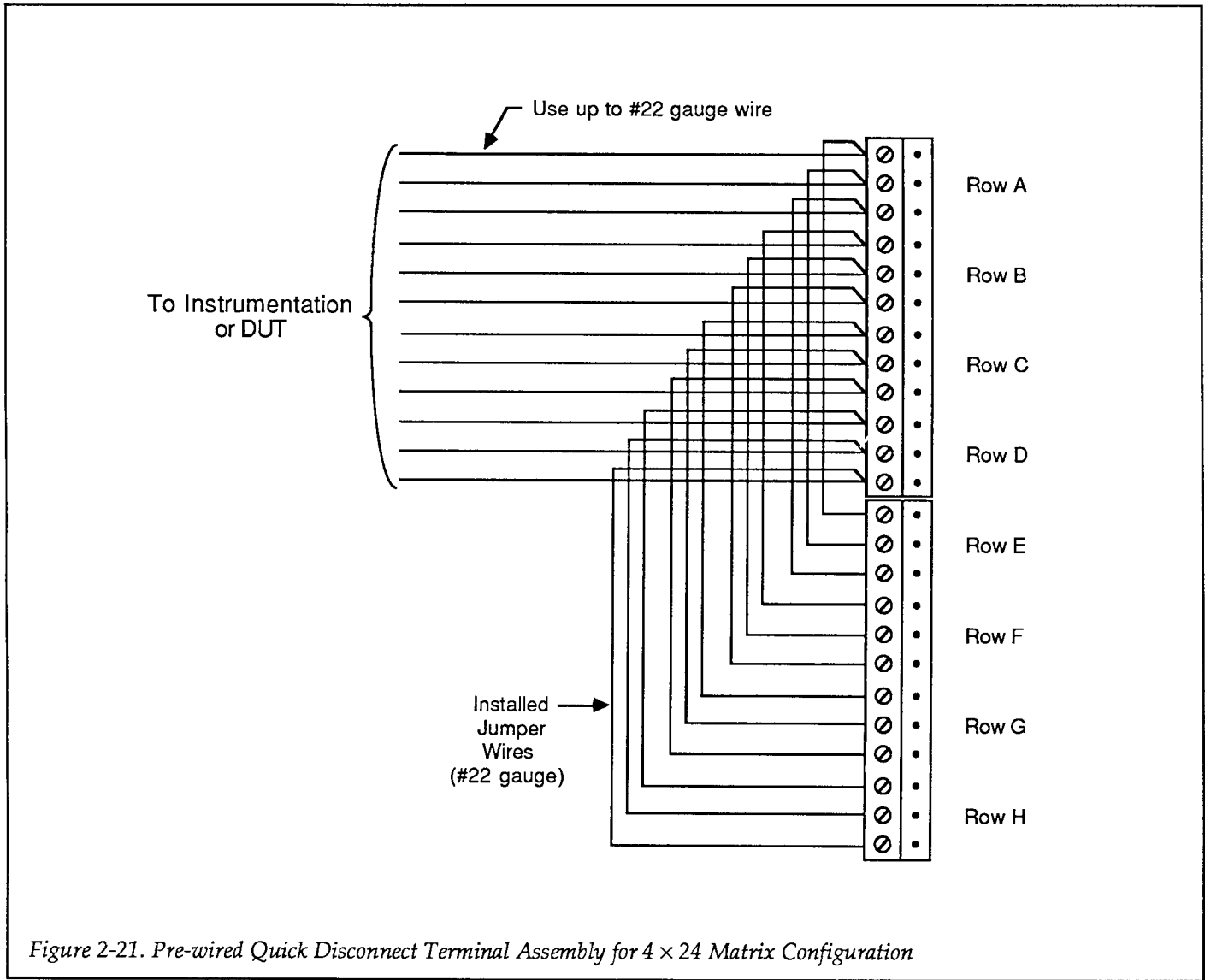

Figure 2-21. Pre-wired Quick Disconnect Terminal Assembly for 4 × 24 Matrix Configuration

2.7 MATRIX EXPANSION

With the use of additional matrix cards, larger matrices can be configured through the backplane of the Model 707. Thus, unless otherwise noted, the examples provided in the following paragraphs assume that the Model 7071-4 backplane jumpers are installed.

2.7.1 Backplane Row Jumpers

The easiest way to to accomplish matrix row expansion is through the backplane of the Model 707 mainframe. It is through this mainframe backplane where row connections to other cards are made. As previously explained in paragraph 2.4 , the Model 7071-4 has eight sets of backplane jumpers that connect the rows of the matrix card to the mainframe backplane.

There is another set of backplane jumpers that must be considered when building larger matrices through rows. This set of backplane jumpers is located in the Model 707 mainframe. With these mainframe backplane jumpers installed, the rows of all mainframe slots are connected together. With these jumpers removed, the rows of mainframe slots 1, 2 and 3 are isolated from the rows of mainframe slots 4, 5 and 6.

NOTE

The Model 707 is shipped with its backplane row jumpers installed. Some configurations require that these backplane row jumpers be removed. The procedure to remove these jumpers can be found in the Model 707 Instruction Manual.

Table 2-5. Narrow Matrix Expansion*

Installed Matrix Cards	Resulting Matrix
1 Card	4 × 24
2 Cards	4 × 48
3 Cards	4 × 72
4 Cards	4 × 96
5 Cards	4 × 120
6 Cards	4 × 144

* Mainframe backplane row jumpers between slots 3 and 4 of mainframe must be installed for a matrix larger than 72 columns.

2.7.2 Narrow Matrix Expansion

An example of a narrow matrix is shown in Figure 2-22. This 4 × 72 matrix is configured by simply installing three "as shipped" Model 7071-4s in the Model 707 mainframe. Rows A, B, C and D are connected to rows E, F, G and H at the instruments rather than at the internal quick-disconnect blocks. This example assumes that that the mainframe backplane jumpers are installed. Every additional Model 7071-4 installed in the mainframe would add 24 columns to the matrix. For example, four Model 7071-4s installed in the mainframe would result in a 4 × 96 matrix. Table 2-5 summarizes the narrow (four rows) matrix possibilities for a single Model 707 mainframe.

Model 7071-4 matrix cards installed in slots 1, 2 and 3 of the Model 707 can be electrically isolated from slots 4, 5 and 6 by removing the mainframe backplane row jumpers. With the jumpers removed, the Model 707 can accommodate two complete, separate matrices using Model 7071-4 matrix cards (see Figure 2-23).

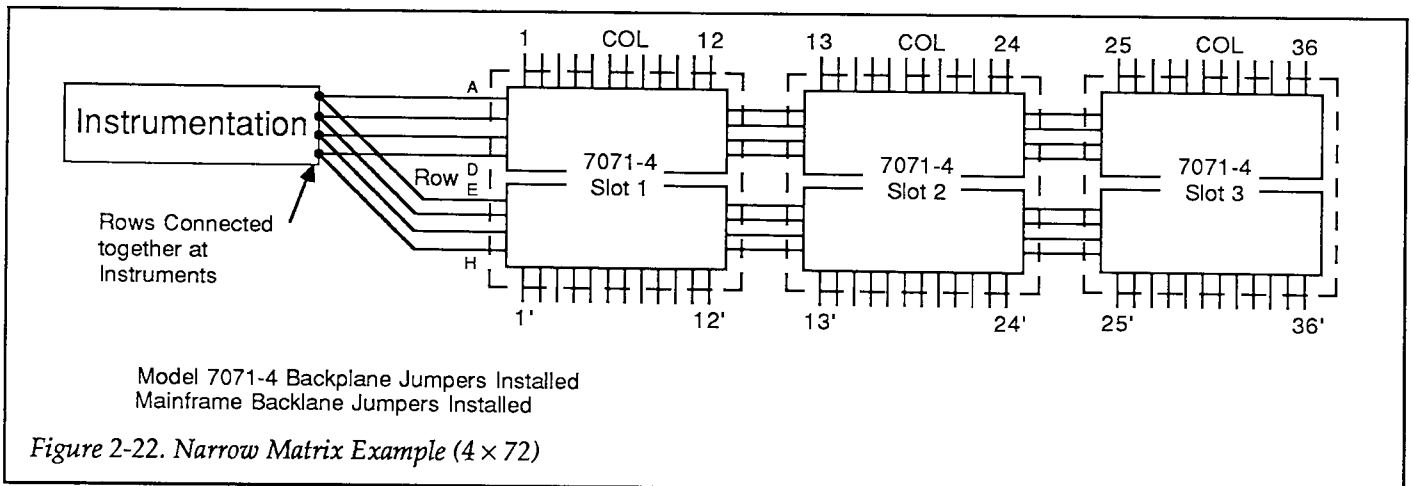

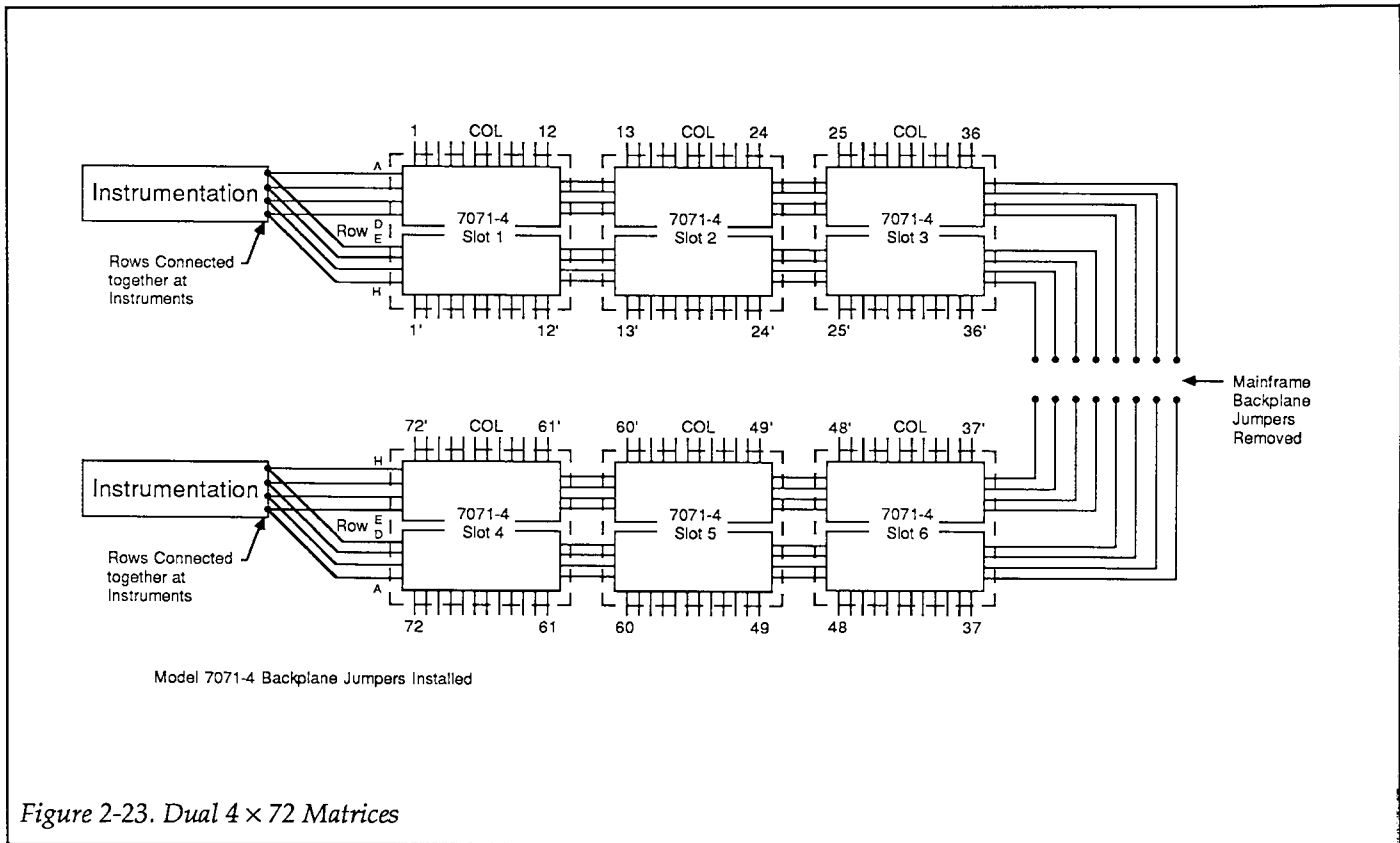

Figure 2-23. Dual 4 x 72 Matrices

2.7.3 Wide Matrix Expansion

By installing the column jumpers of the Model 7071-4, the card becomes configured as an 8 x 12 matrix (see paragraph 2.4.2). Assuming that the backplane jumpers of the Model 707 and 7071-4s are installed, each 8 x 12 matrix card installed in the mainframe extends the matrix by 12 columns. For example, three Model 7071-4s (configured as 8 x 12 matrices) installed in the Model 707 will result in an 8 x 36 matrix. An example of an 8 x 36 matrix is shown in Figure 2-24. Table 2-6 summarizes the wide (eight rows) matrix possibilities for a single Model 707 mainframe.

With the column jumpers installed, column 1 is connected to column 1', column 2 is connected to column 2' and so on. Thus, when connecting DUT or instrumentation to the columns of the matrix, it is recommended that only one column's "rack and panel" connector be used.

NOTE

With the column and backplane jumpers installed, the Model 7071-4 is operationally

identical to the Model 7071 General Purpose Matrix Card. Thus, the Model 7071-4, configured in this manner, is interchangeable with the Model 7071.

2.7.4 Partial Matrix Implementation

A fully implemented matrix provides a relay at each potential crosspoint. For example, a fully implemented 8 x 36 matrix utilizing three 8 x 12 matrix cards contains 288

Table 2-6. Wide Matrix Expansion*

Installed Matrix Cards	Resulting Matrix
1 Card	8 x 12
2 Cards	8 x 24
3 Cards	8 x 36
4 Cards	8 x 48
5 Cards	8 x 60
6 Cards	8 x 72

* Mainframe backplane row jumpers between slots 3 and 4 of mainframe must be installed for a matrix larger than 36 columns.

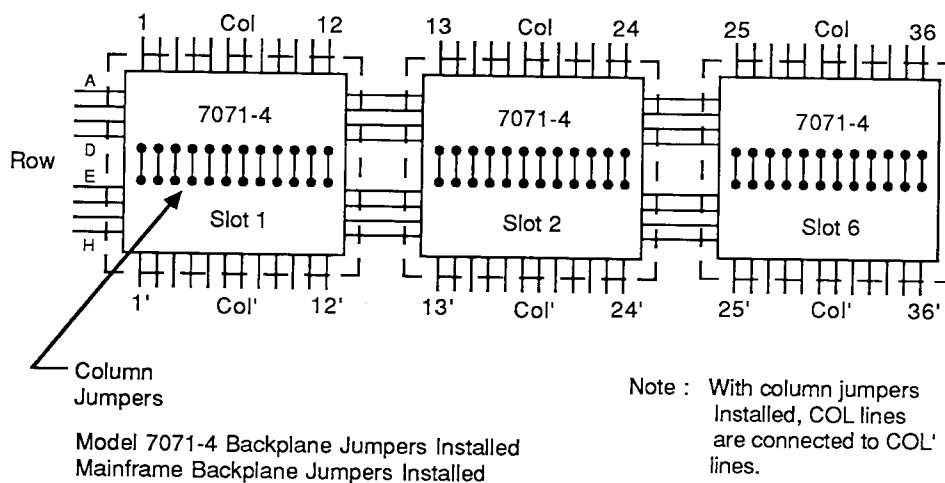

Figure 2-24. Wide Matrix Example (8×36)

crosspoints. A partially implemented 8×36 matrix would contain fewer crosspoints. An example of a partially implemented 8×36 matrix is shown in Figure 2-25. The partial matrix is still 8×36 , but contains only 192 crosspoints using two matrix cards. The Model 7071-4 is configured as a 4×24 matrix. Notice in Figure 2-25A that the Model 7071-4 backplane jumpers for rows E through H are cut. These jumpers must be cut in order to isolate the Model 7071-4 from rows E through H of the other matrix card (in this case, a Model 7071) in the mainframe (see Figure 2-25B).

An obvious advantage of a partial matrix is that fewer matrix cards are needed. Another reason to use a partial matrix is to keep certain devices from being connected directly to other certain devices. For example, a source in Figure 2-25B cannot be connected to a column of the Model 7071-4 with one "accidental" crosspoint closure. Three specific crosspoints must be closed in order to connect a source to a Model 7071-4 column.

2.7.5 Mainframe Matrix Expansion

Matrices using up to 30 matrix cards are possible by daisy-chaining five Model 707 mainframes together. Using 30 Model 7071-4 matrix cards provides 2880 crosspoints.

In general, assuming all backplane jumpers are installed, connecting the rows of a card in one mainframe to the rows of a card in a second mainframe increases the column numbers of the matrix. For example, if the rows of a 4×120 matrix in one mainframe are connected to the rows of a 4×72 matrix in a second mainframe, the resulting matrix would be 4×192 . See the Model 707 Instruction Manual for detailed information on daisy-chaining Model 707 mainframes.

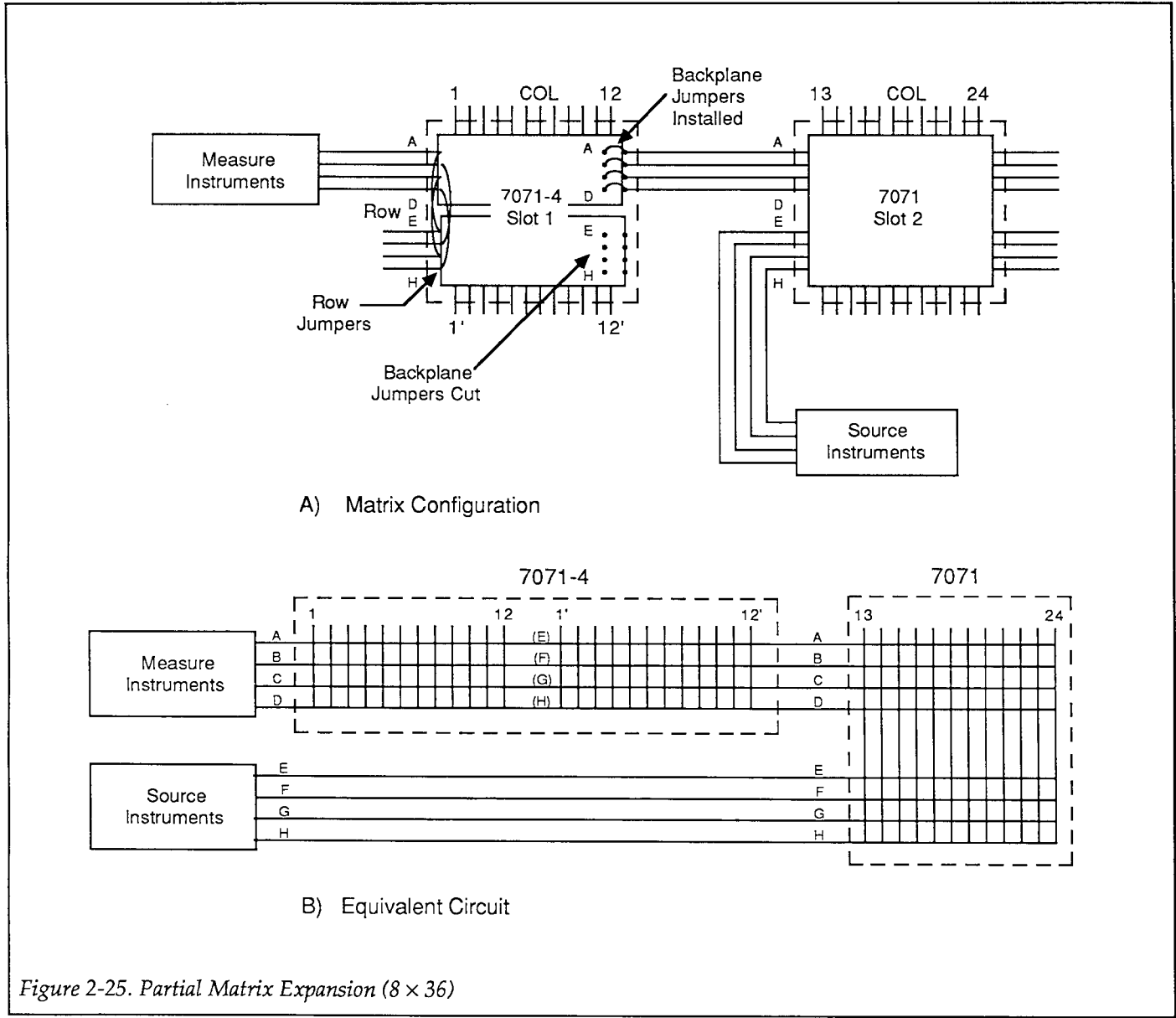

Figure 2-25. Partial Matrix Expansion (8 x 36)

2.8 TYPICAL CONNECTION SCHEMES

The information in this paragraph provides some typical connection schemes for single card, multiple card and multiple mainframe system configurations. Also, a system using the matrix card with a multiplexer card (Keithley Model 7074) is shown to demonstrate versatility and compatibility. All of the examples use Model 7071-4s configured as 4×24 matrices. Also, the examples show Model 7078-MTC cables cut in half. These cables could just as well be custom built cables to better suit a particular application.

2.8 .1 Single Card System

Figure 2-26 shows how external connections for a single card system might be made. Instrumentation is connected to matrix card rows. Using standard instrument cables that are unterminated at one end makes it convenient to make connections at the quick-disconnect terminal blocks of the matrix card. A Model 7078-MTC cable, cut in half, is used to connect DUTs to matrix card columns.

2.8 .2 Multiple Card System

Figure 2-27 shows a system using two matrix cards. In this configuration, both instrumentation and DUT are connected to the columns of the matrix using two Model 7078-MTC cables that are cut in half. In this example, the instruments are connected to the columns because they require six pathways. The matrix, as configured, has only four rows.

2.8 .3 Multiple Mainframe System

Figure 2-28 shows a system using seven matrix cards, requiring two Model 707s daisy-chained together. In this configuration DUTs are connected to matrix card columns using seven Model 7078-MTC cables cut in half. A single Model 7078-MTC cable is used to connect the rows of the master mainframe to the rows of the slave mainframe. Note that if path resistance is a critical factor, use a cable that is as short as possible, such as the Model 7078-MTC-5 which is five feet in length. A Model 7078-MTC cable can be shortened or a custom cable can be built using two Model 7078-KIT connector kits.

2.8 .4 Matrix/Multiplexer System

Figure 2-29 shows an example of how the Model 7071-4 can be used along with a multiplexer card (Keithley Model 7074) in the same test system. In this example, the Model 7071-4 is configured as a 4×24 matrix and the Model 7074 is configured as a quad 1×24 multiplexer. In this test system, the matrix card provides 24 columns for DUT or additional instrumentation. By using the multiplexer card in the system, 96 additional test lines are made available.

Different bank jumper/backplane jumper combinations on the Model 7074 can provide different pin outs for the same quad 1×24 multiplexer configuration. Also, different multiplexer configurations are easily accomplished. For example (refer to Figure 2-29), removing backplane jumpers for rows C and F, and installing bank jumpers B to C and F to G will configure the card as a dual 1×48 multiplexer.

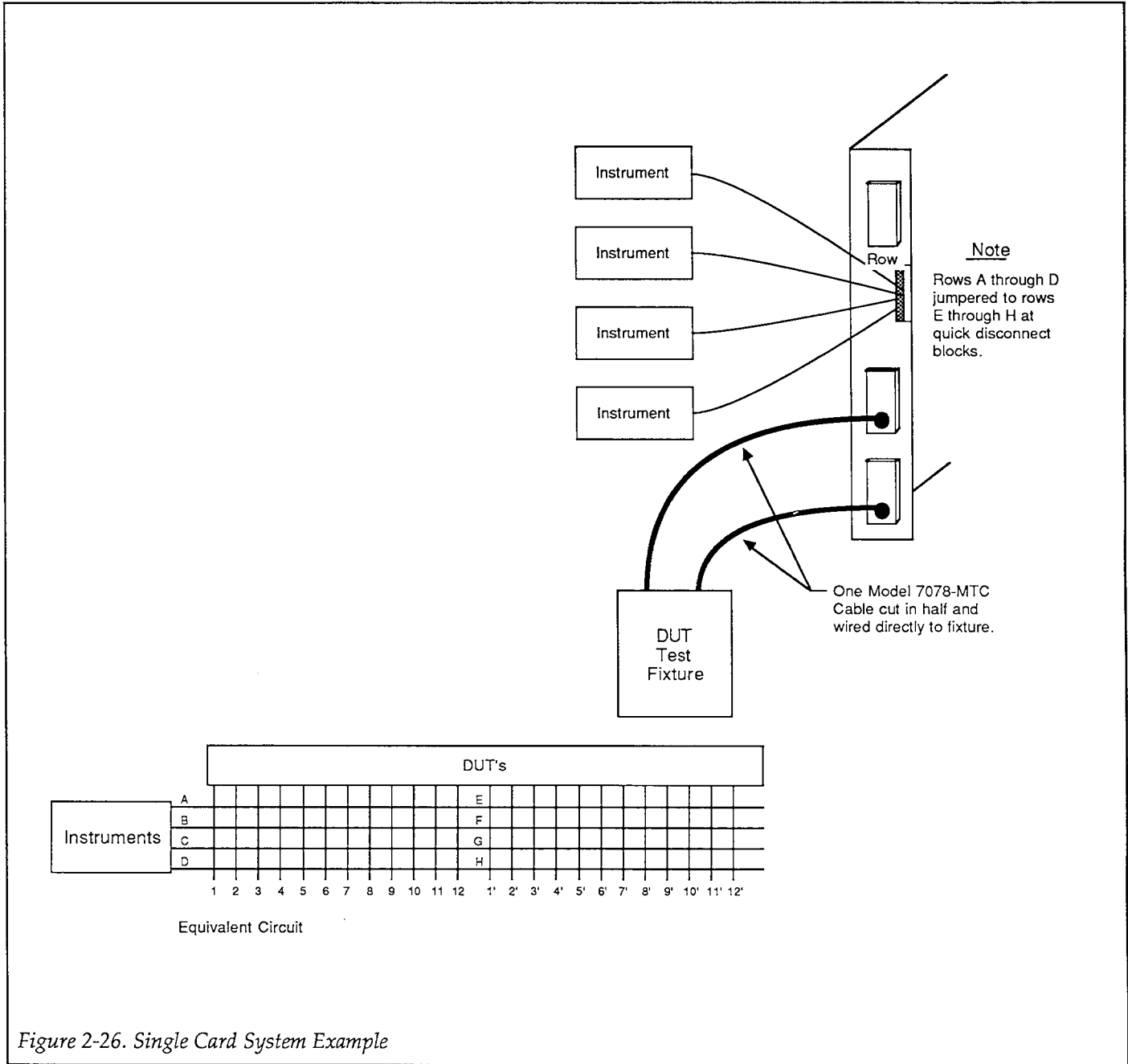
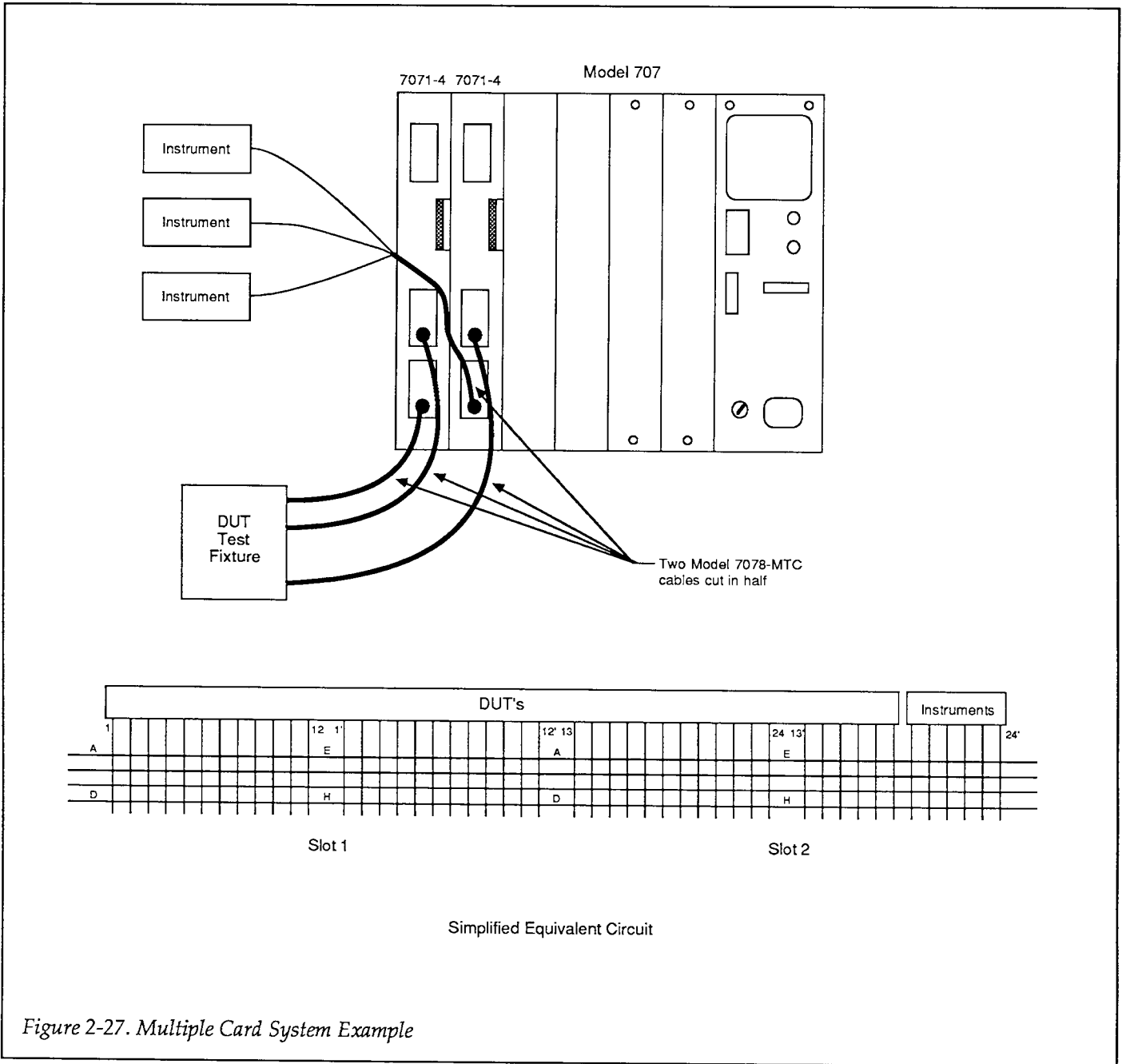

Figure 2-26. Single Card System Example



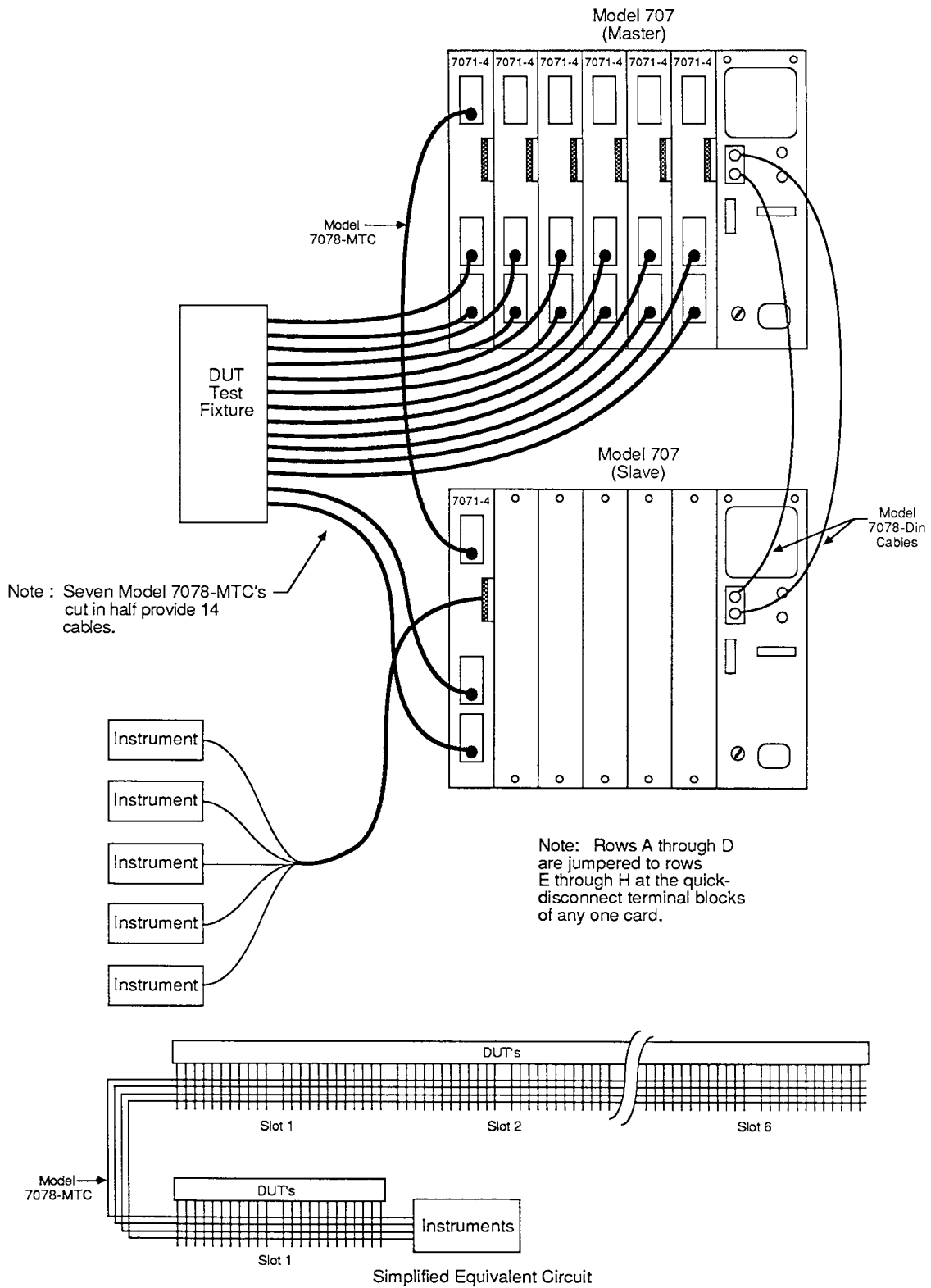

Figure 2-28. Multiple Mainframe Example

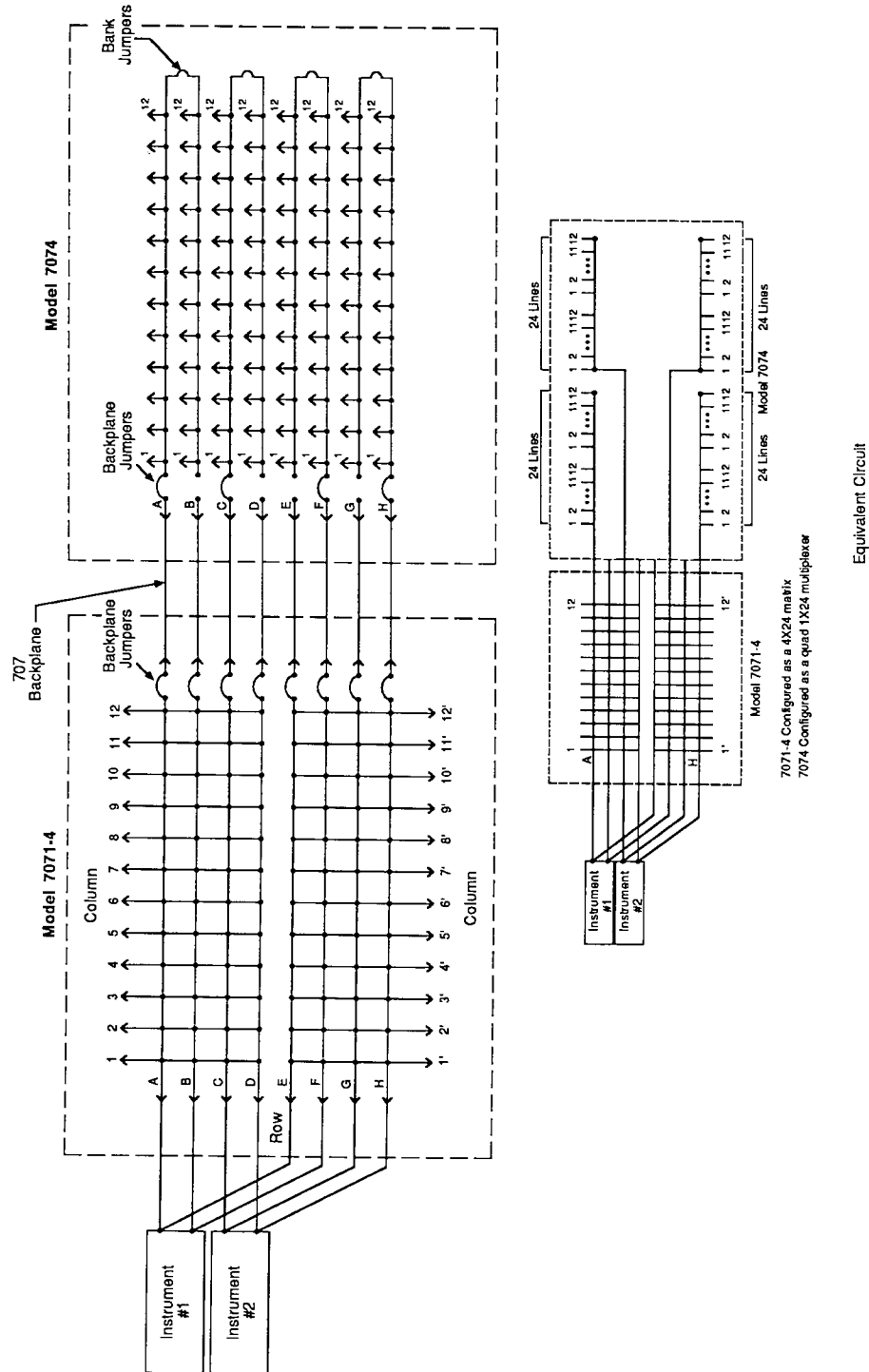

Figure 2-29. Matrix/Multiplexer System

SECTION 3

Applications

3.1 INTRODUCTION

General applications to test thick film resistor networks and transistors are provided in this section. These applications are intended to demonstrate the versatility of using the matrix card in test systems.

The first application (Thick Film Testing) uses the Model 7071-4 as a 4 × 24 matrix and the second application (Transistor Testing) uses the card as an 8 × 12 matrix.

3.2 THICK FILM RESISTOR NETWORK TESTING

A dedicated matrix system for testing thick film resistor networks is shown in Figure 3-1. This particular system provides two different methods to check thick films; four-wire resistance measurements, and voltage measurements using an applied voltage. The Model 7071-4 used in this system is configured as a 4 × 24 matrix.

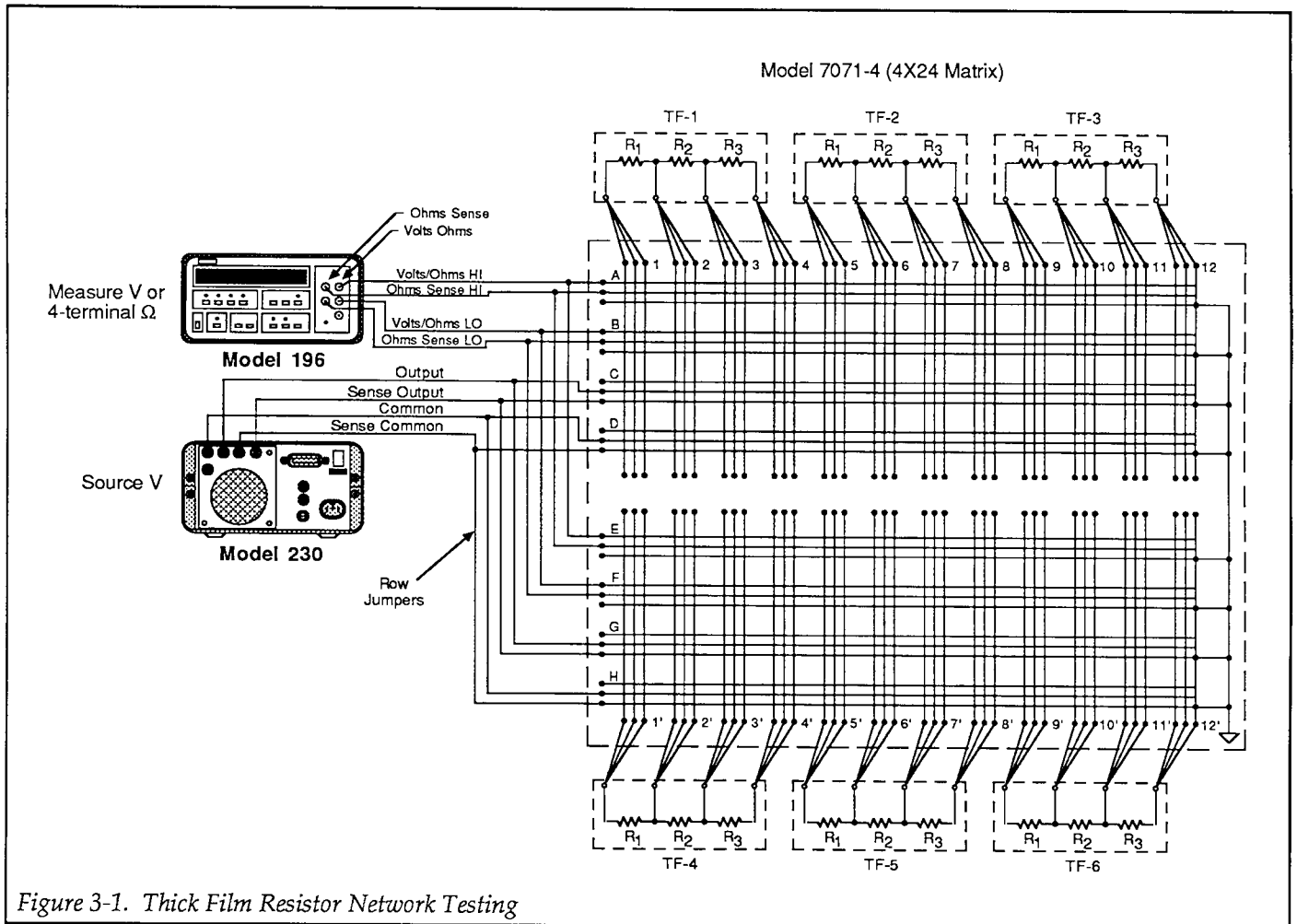

Figure 3-1. Thick Film Resistor Network Testing

The system shown in Figure 3-1 tests six 3-element thick films, but can be expanded to test more by simply using additional Model 7071-4 matrix cards. The Model 707 will accommodate six matrix cards. Daisy-chaining five Model 707s expands the system to 30 matrix cards allowing 180 three-element thick films to be tested.

3.2.1 Four-terminal Ohms Measurements

For general purpose testing, the Keithley Model 196 can be used to make four-terminal resistance measurements of each thick film. As shown in Figure 3-2, OHMS HI and

OHMS SENSE HI are connected to one matrix row, and OHMS LO and OHMS SENSE LO are connected to another matrix row. The third pole (G) of the matrix is not shown since it is not used. With this configuration, the resistance of each resistor element and/or combined elements can be measured by closing the appropriate crosspoints. In Figure 3-2, crosspoints A1 (row A, column 1) and B3 are closed to measure the combined resistance of R1 and R2.

The effects of thermal EMFs generated by relay contacts and connections can be canceled by using the offset compensated ohms feature of the Model 196. To compensate for thermal EMFs, close two crosspoints (such as A1 and B1) that will short the input of the Model 196, enable zero

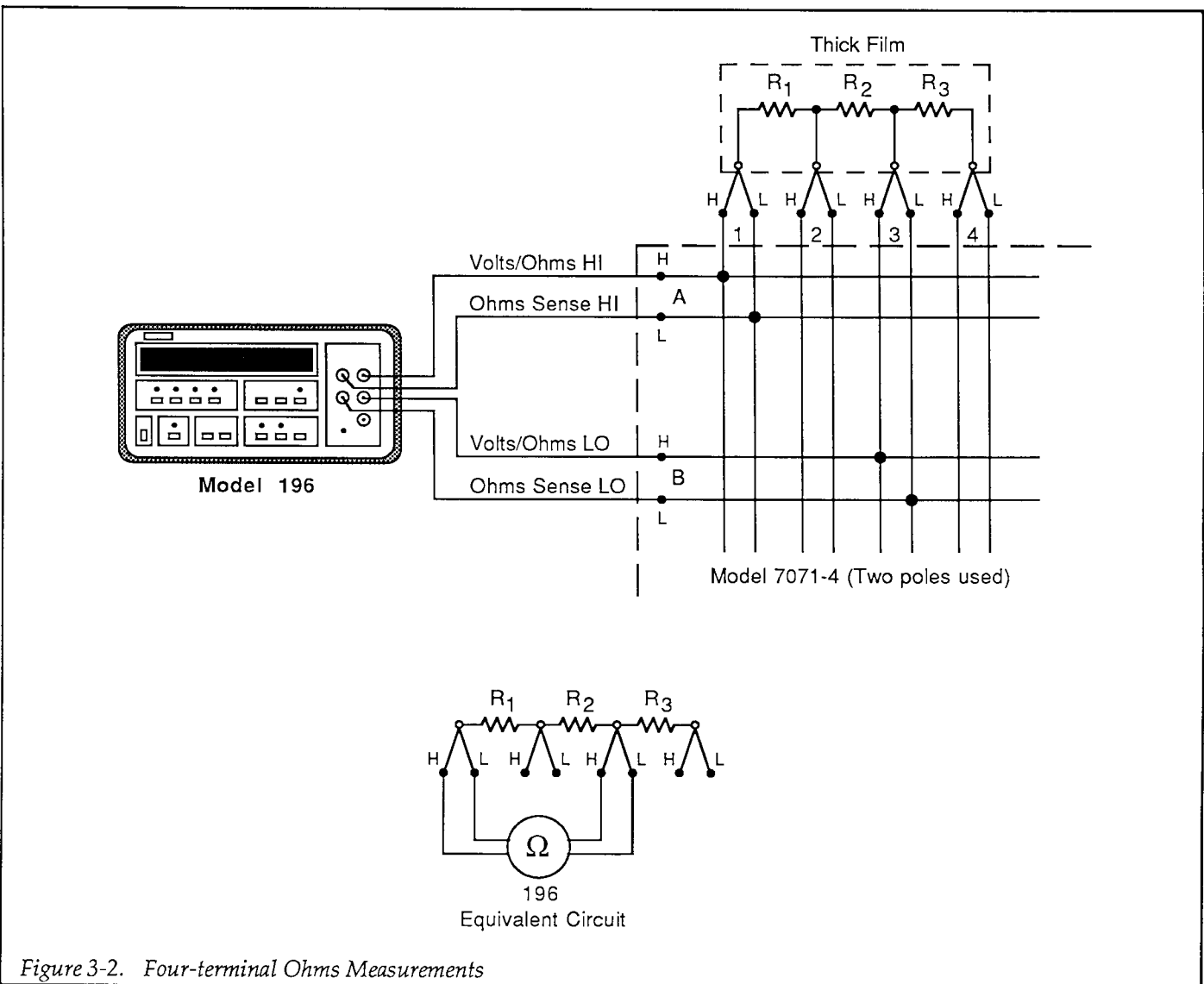

Figure 3-2. Four-terminal Ohms Measurements

to cancel internal offset, and then enable offset compensated ohms.

3.2 .2 Voltage Divider Checks

For thick film resistor networks that are going to be used as voltage dividers, it may be desirable to test them using voltages that simulate actual operating conditions. This is a particularly useful test for resistor networks that have a voltage coefficient specification. The test system in Figure 3-1 uses a Keithley Model 230 to source voltage and the Model 196 to measure voltage.

A consideration in these checks is the affect of the Model 196 input impedance on voltage measurements. The input impedance is shunted across the resistor being measured. The resultant divider resistance is the parallel combination of the resistor under test and the input impedance. As long as the input impedance is much larger than the resistor being tested, the error introduced into the measurement will be minimal. Minimum input impedance requirements are, of course, determined by the accuracy needed in the measurement. The input impedances of the Model 196 are as follows: 300mV and 3V

ranges, 1G Ω ; 30V range, 11M Ω ; 300V range, 10.1M Ω . For better input impedance requirements, the Keithley Model 617 Electrometer can be incorporated into the test system to measure voltage.

Another factor to be considered when checking low voltage dividers is thermal EMFs generated by the matrix card. A matrix card crosspoint can generate up to $\pm 5\mu\text{V}$ of thermal EMF. Thus, when making low voltage measurements be sure to account for this additional error.

Even though four-terminal connections are made at the Model 196 and the resistor networks, the sense leads are internally disconnected from the input of the DMM when the volts function is selected. The simplified test system is shown in Figure 3-3.

The thick film is tested by applying a voltage across the resistor network and measuring the voltage across each resistor element and/or across combined elements. In Figure 3-3, crosspoints C1 and D4 are closed to apply voltage across the network, and crosspoints A3 and B4 are closed to measure the voltage drop across R3.

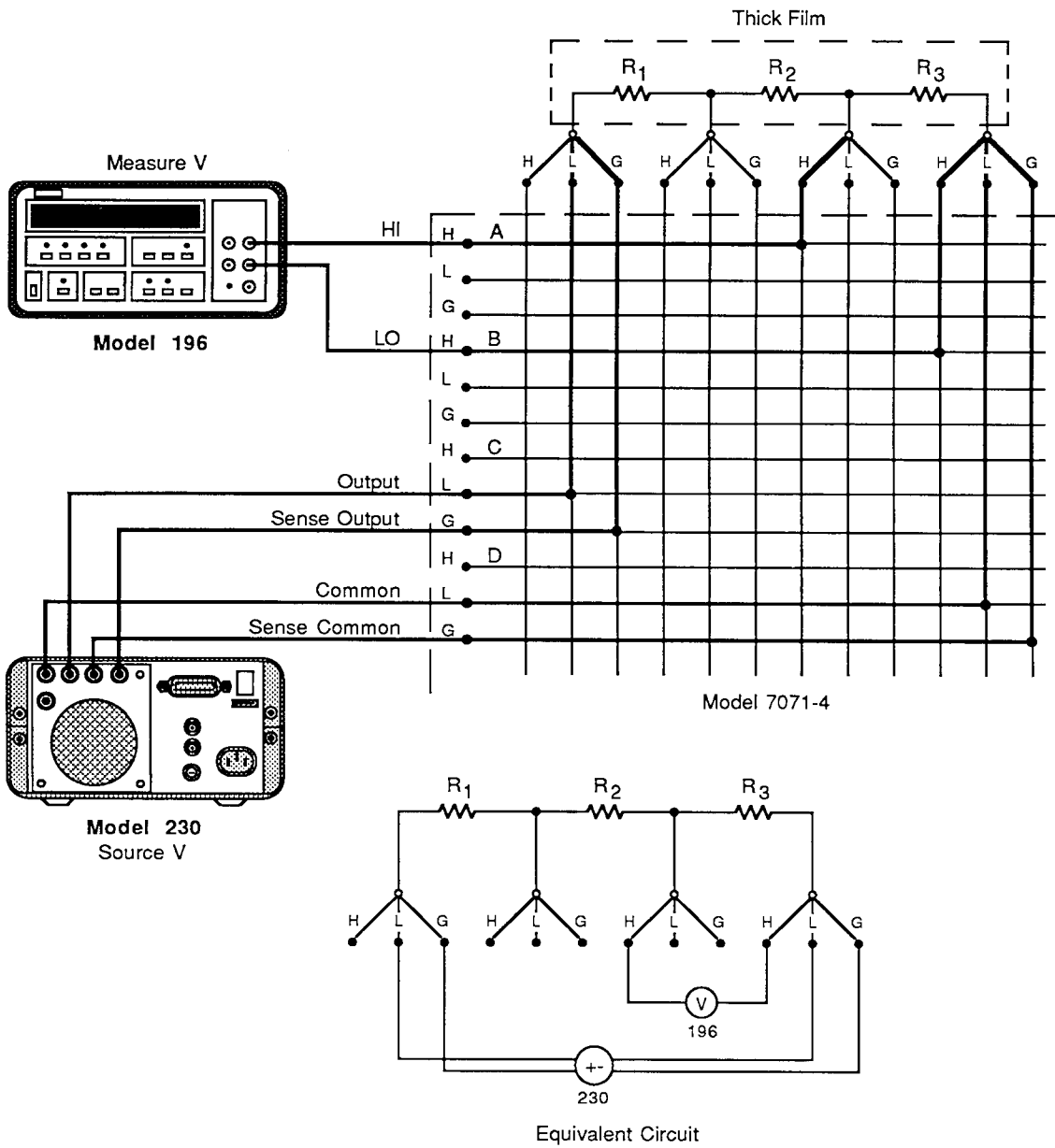

Figure 3-3. Voltage Divider Checks

3.3 TRANSISTOR TESTING

A matrix system for testing dc parameters of transistors is shown in Figure 3-4. The Model 7071-4 is configured as an 8 × 12 matrix. This system uses a current source (Keithley Model 224), a voltage source (Keithley Model 230) and a DMM (Keithley Model 196) to measure current and/or voltage. This system tests three transistors, but can be expanded to test more by simply using additional Model 7071-4 matrix cards. The Model 707 will accommodate six matrix cards. Daisy-chaining five Model

707s expands the system to 30 matrix cards allowing 90 transistors to be tested.

NOTE

To check FETs or transistors that have high gain or low power, equipment that has lower offset current and higher impedance must be used. To check these devices, the Keithley Model 7072 Semiconductor Matrix Card and the Keithley Model 617 Electrometer can be used.

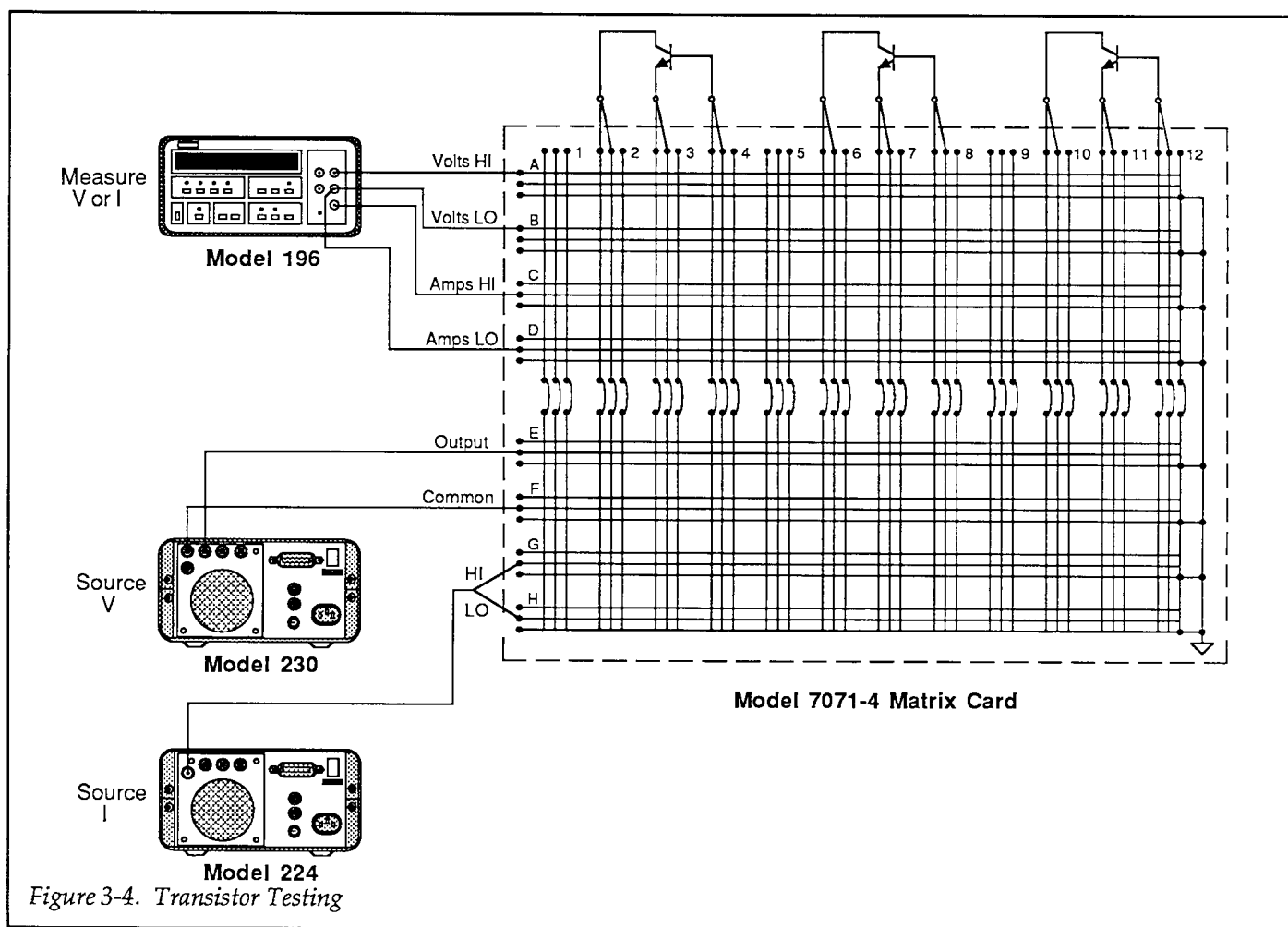

Figure 3-4. Transistor Testing

3.3 .1 Current Gain Checks

The dc current gain of a general purpose transistor can be checked by configuring the transistor as a common-emitter amplifier. Figure 3-5 shows which crosspoints to close to configure the amplifier circuit. In this circuit, gain is calculated by dividing collector current (measured by the Model 196) by base current (sourced by the Model 224). A profile of the transistor operating characteristics can be obtained by measuring the collector current over a specified voltage range (V_{CE}) for different base bias currents. For example, Figure 3-6 shows the characteristics of a typical NPN silicon transistor at base bias currents (I_B) of $20\mu A$, $40\mu A$, $60\mu A$ and $80\mu A$.

3.3 .2 I_E and V_{BE} Measurements

The versatility of using a matrix is demonstrated in Figure 3-7 and Figure 3-8. The transistor is still configured as a common-emitter amplifier, but the Model 196 is removed from the collector circuit and used to measure emitter current and base-to-emitter voltage. Notice that external connection changes are not required. All connection changes are accomplished by control of matrix crosspoints. In this situation, care must be taken to prevent crosspoints of rows B and D from being closed at the same time.

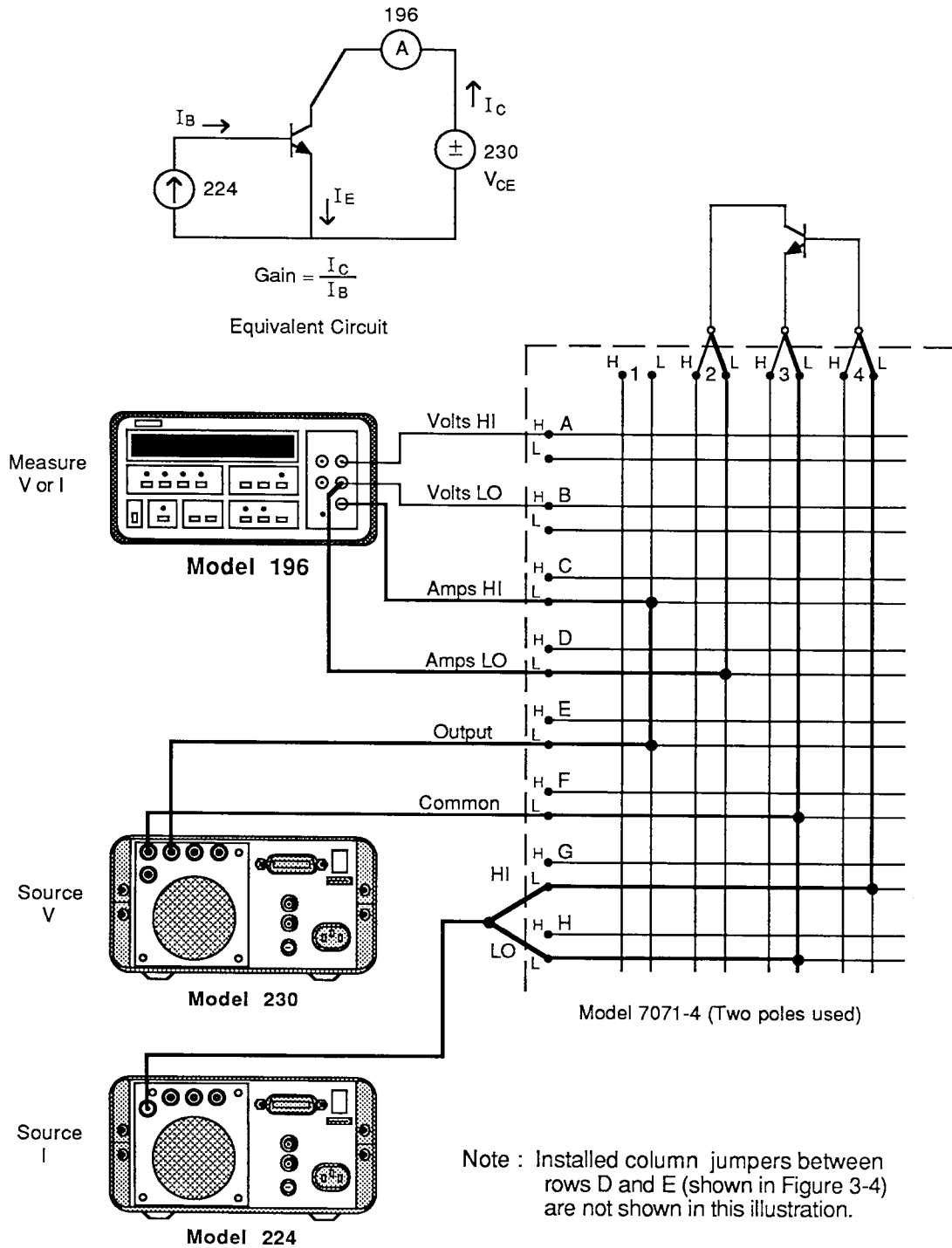

Figure 3-5. Transistor Current Gain Checks

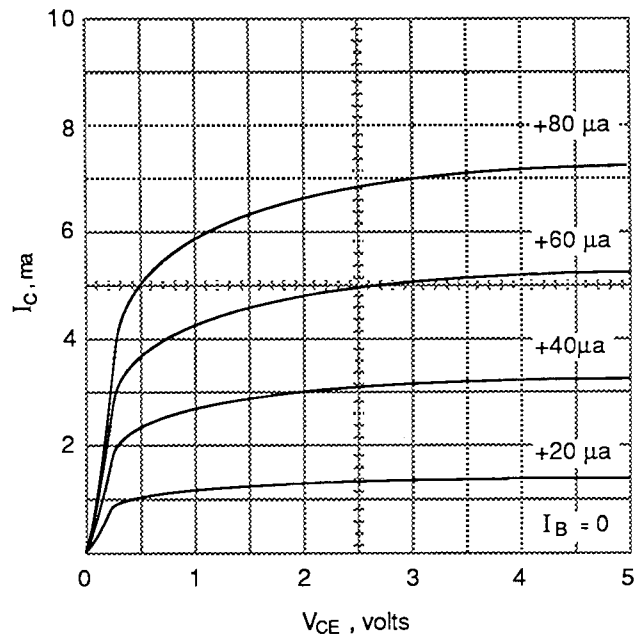

Figure 3-6. Common-Emitter Characteristics of an NPN Silicon Transistor

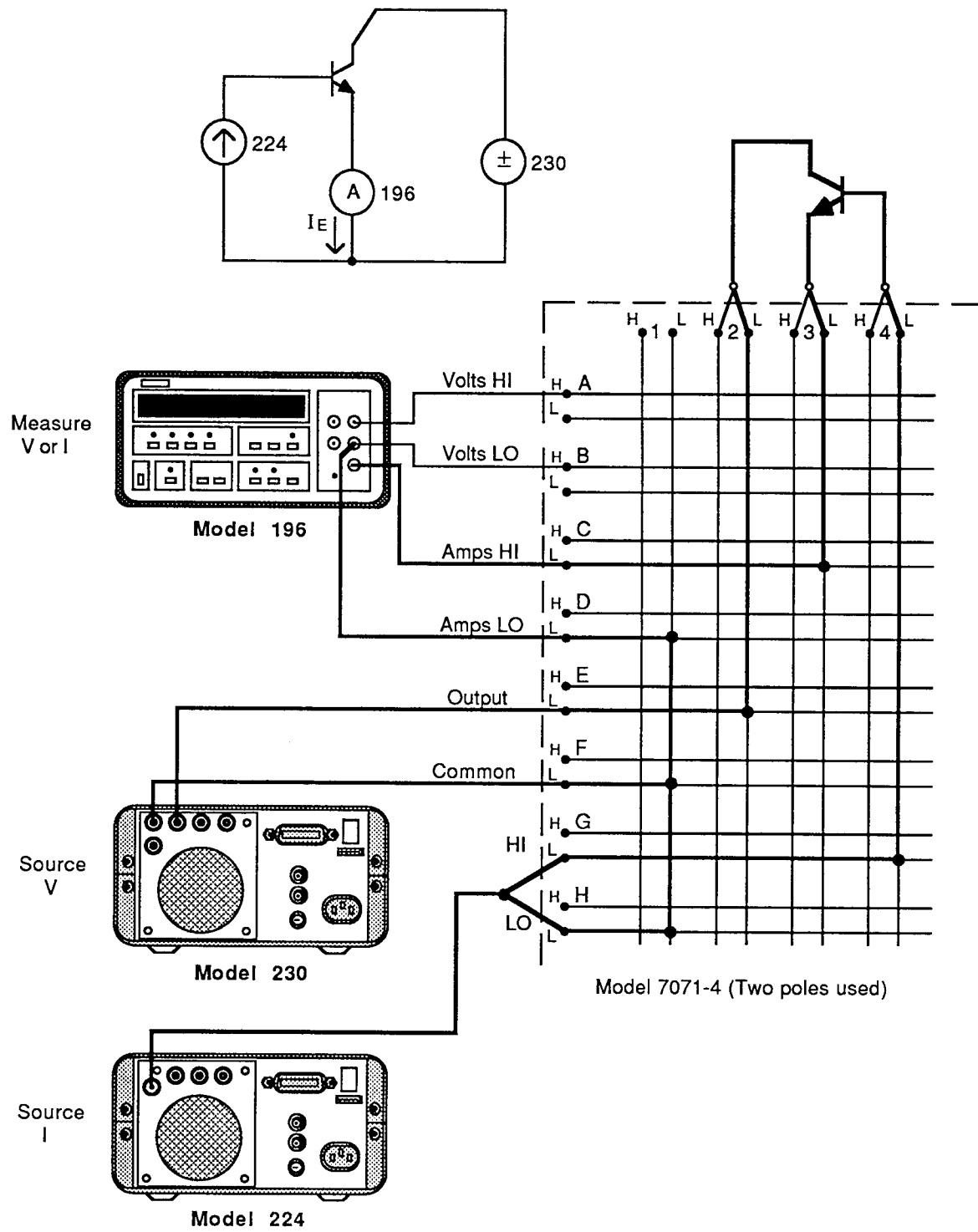

Figure 3-7. Transistor I_E Measurements

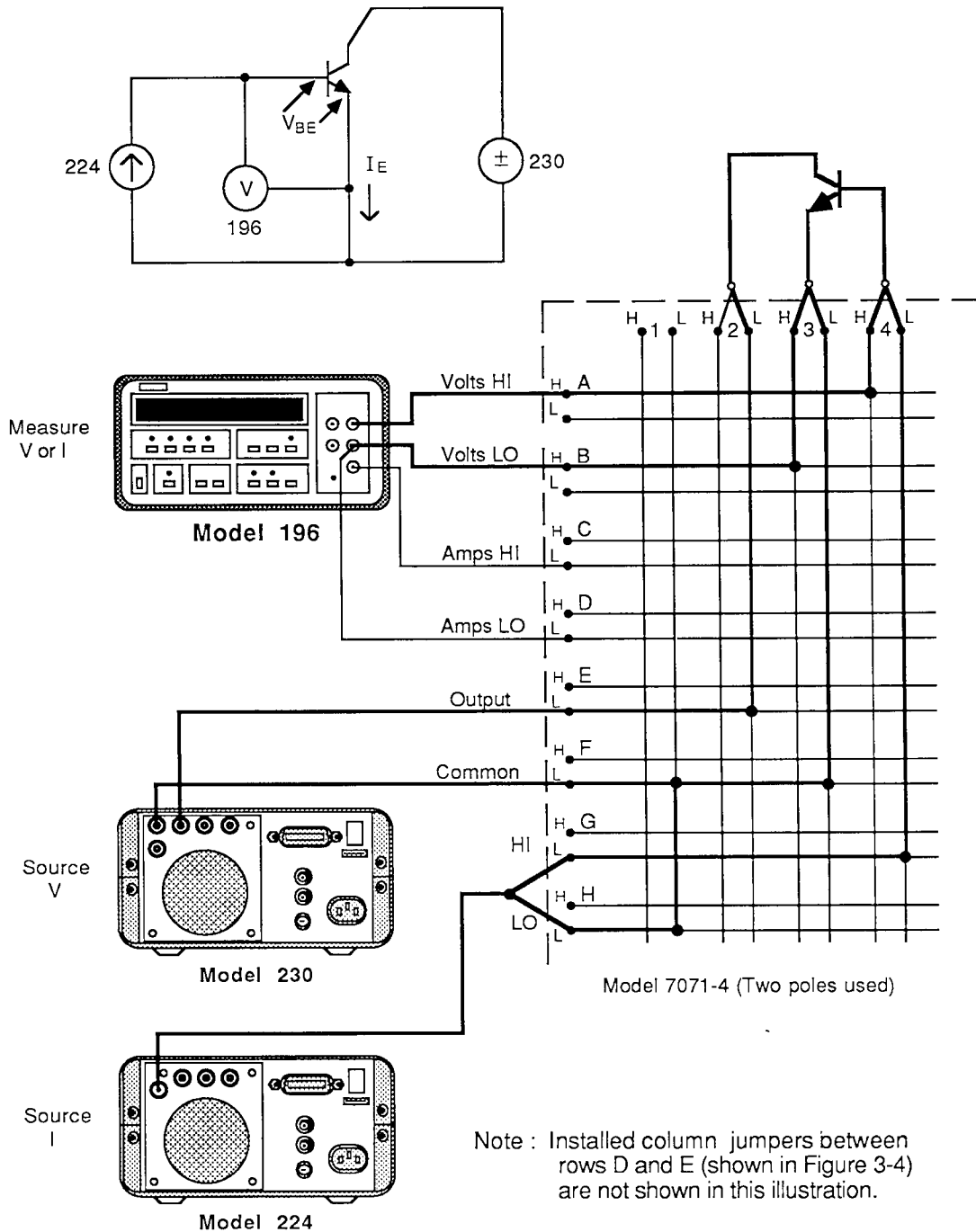

Figure 3-8. Transistor V_{BE} Measurements

SECTION 4

Service Information

4.1 INTRODUCTION

This section contains information necessary to service the Model 7071-4 and is arranged as follows:

4.2 Handling and Cleaning Precautions: Discusses handling procedures and cleaning methods for the matrix card.

4.3 Relay Test Program: Explains how to connect the matrix card to the Model 707 mainframe for the relay test program.

4.4 Performance Verification: Covers the procedures necessary to determine if the card is operating properly.

4.5 Principles of Operation: Briefly discusses circuit operation.

4.6 Special Handling of Static-Sensitive Devices: Reviews precautions necessary when handling static-sensitive devices.

4.7 Troubleshooting: Presents some troubleshooting tips for the matrix card.

4.2 HANDLING AND CLEANING PRECAUTIONS

Because of the high impedance circuits on the Model 7071-4, care should be taken when handling or servicing the card to prevent possible contamination, which could degrade performance. The following precautions should be taken when handling the matrix card.

1. Do not store or operate the card in an environment where dust could settle on the circuit board. Use dry nitrogen gas to clean dust off the card if necessary.

2. Handle the card only by the handle and side edges. Do not touch any board surfaces, components, or edge connectors. Do not touch areas adjacent to electrical contacts. When servicing the card, wear clean, cotton gloves.
3. If making solder repairs on the circuit board, use a flux that is rosin RMA based. Remove the flux from these areas when the repair is complete. Use Freon® TMS or TE, or the equivalent along with plenty of clean cotton swabs to remove the flux. Take care not to spread the flux to other areas of the circuit board. Once the flux has been removed, swab only the repaired area with methanol, then blow dry the board with dry nitrogen gas.
4. After cleaning, the card should be placed in a 50°C low humidity environment for several hours.

4.3 RELAY TEST PROGRAM SET-UP

The Model 707 comes equipped with a test program on disk that will test the relays of all Model 7071-4s installed in the mainframe. The test program will flag any relay that fails to close when energized or open when de-energized. Instructions for using the test program with an IBM PC or XT, or HP 200 or 300 series computer are contained in the Model 707 Instruction Manual.

Perform the following steps to configure the Model 7071-4 for relay testing:

1. Remove the relay test terminal block from the rear panel of the Model 707. This is a quick-disconnect terminal block and simply pulls off the rear panel terminal strip.
2. Connect the relay test terminal block to rows A and B of any Model 7071-4 card installed in the mainframe as shown in Figure 4-1. Note that terminals 5 and 6 of the relay test terminal block must be shorted together. Terminals H, L, and G of row B of the Model 7071-4 must also be shorted together.
3. Re-install the relay test terminal block into the rear panel of the Model 707 mainframe and refer to the Model 707 Instruction Manual to run the test program.

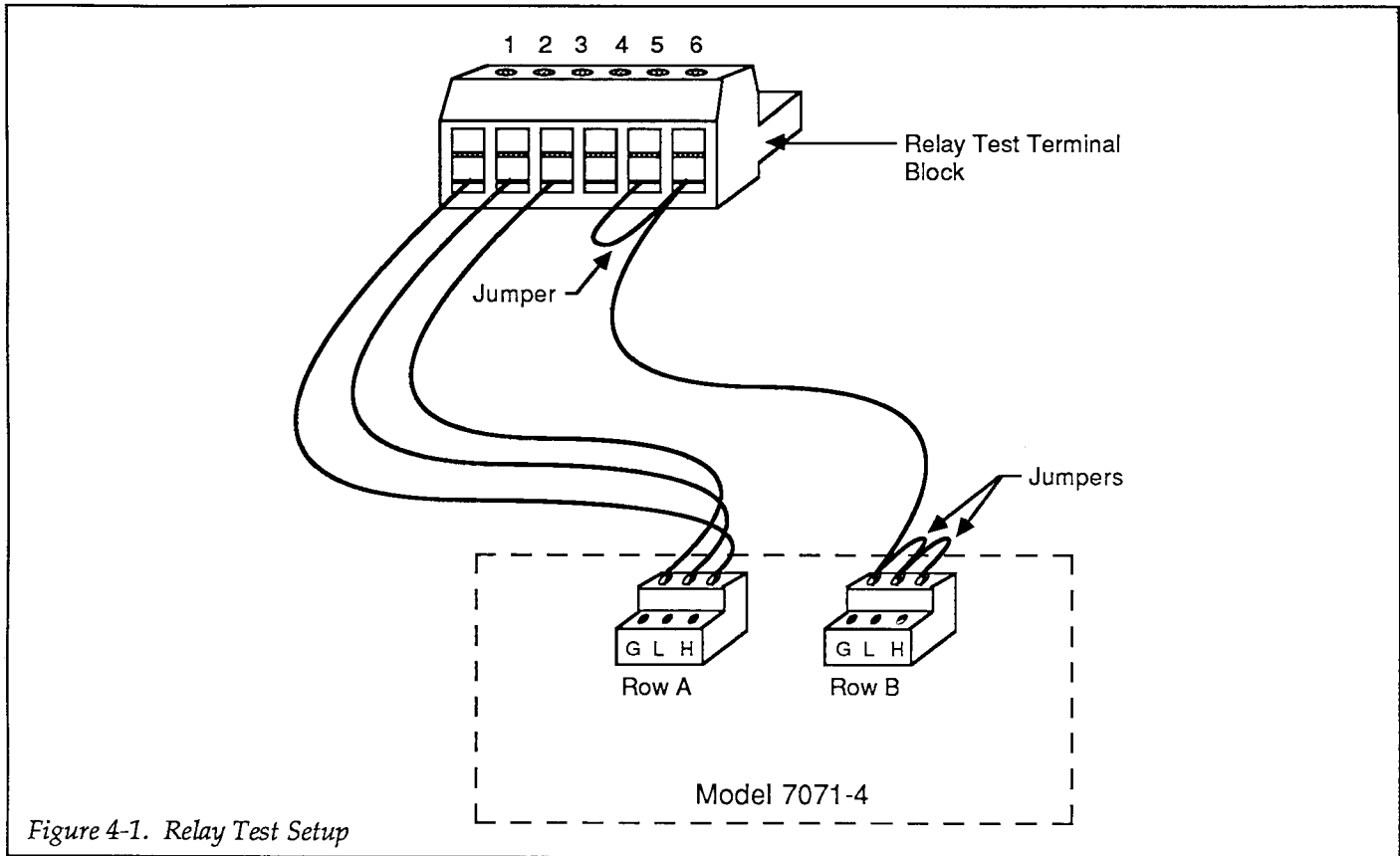

Figure 4-1. Relay Test Setup

4.4 PERFORMANCE VERIFICATION

The following paragraphs discuss performance verification procedures for the Model 7071-4, including path resistance, offset current, contact potential, and isolation.

The procedures in this section are rather lengthy due to the large number of row and column combinations that are checked. As an alternative to this extensive testing, it may be desirable to check only those paths that are going to be used, or those that are suspected of being faulty.

The procedures in this section make external equipment connections to matrix rows at the terminal strip on the PC board. If using the "rack and panel" ROWS receptacle to make connections, modify the procedures accordingly. Connection techniques to "rack and panel" receptacles are covered in Section 2.

With the Model 7071-4's backplane jumpers installed, the performance verification procedures must be performed with only one matrix card (the one being checked) in-

stalled in the Model 707 mainframe. Also, the Model 707 must not be daisy-chained to another Model 707. These conditions do not apply if the jumpers are already removed.

CAUTION

Contamination will degrade the performance of the matrix card. To avoid contamination, always grasp the card by the handle and side edges. Do not touch the edge connectors of the card, and do not touch the board surfaces or components. On "rack and panel" connectors and quick-disconnect terminal blocks, do not touch areas adjacent to the electrical contacts.

NOTE

Failure of any performance verification test may indicate that the matrix card is contaminated. See paragraph 4.2 to clean the card. If the test still fails after cleaning, then try cleaning the backplane (see the Model 707 Instruction Manual).

Table 4-1. Verification Equipment

Description	Model or Part	Specifications	Applications
DMM	Keithley Model 196	300Ω; 0.01%	Path resistance
Electrometer w/voltage source	Keithley Model 617	10pA, 100pA; 1.6% 100V source; 0.2%	Offset current, path isolation
Nanovoltmeter	Keithley Model 181	2mV; 0.015%	Contact potential
Triax cable (unterminated)	Keithley Model 7025	—	Offset current
Low thermal cable (unterminated)	Keithley Model 1484	—	Contact potential
Wire crimp tail	Keithley CS-426	—	Column jumper wires
Hand crimping tool	Keithley Model 7078-HCT	—	Crimp wire tails to jumper

4.4 .1 Environmental Conditions

All verification measurements should be made at an ambient temperature between 18° and 28°C, and at a relative humidity of less than 70%.

4.4 .2 Recommended Equipment

Table 4-1 summarizes the equipment necessary for performance verification, along with an application for each unit.

NOTE

Do not use the Model 7070 Universal Adapter Card as an extender card to verify performance of the Model 7071-4. The Model 7071-4 must be installed in the Model 707 main-frame.

4.4 .3 Initial Preparation

All of the performance verification tests require that the internal column jumpers be installed, resulting with an 8 × 12 matrix. See paragraph 2.4 .2 to install the jumpers.

Some of the tests require that additional column terminals be jumpered together. The most convenient method to jumper column terminals is at the COLUMN receptacles using custom built jumper wires terminated with wire crimp tails (Keithley P/N CS-426). The wire crimp tails of these jumpers will mate to the crimp tails of the COLUMN receptacles. Use clean #18 to #26 gage copper wire for the jumpers. Each jumper should be no more than a couple of inches in length to minimize path resistance. The Keithley Model 7078-HCT Hand Crimping Tool can be used to attach the crimp tails to the copper wires. A total of 35 jumper wires are needed.

4.4 .4 Path Resistance Tests

Perform the following steps to verify that each contact of every relay is closing properly and that the resistance is within specification.

NOTE

Refer to Figure 4-2 for the following procedure.

1. Turn the Model 707 off if it is on.
2. Using the prepared jumper wires, connect all terminals of the matrix columns together to form one common terminal. Terminal identification is provided in Figure 2-13. Notice that that the wiring side of the COLUMN receptacle is shown. Thus, the contact side of the receptacle is the mirror image of that drawing.

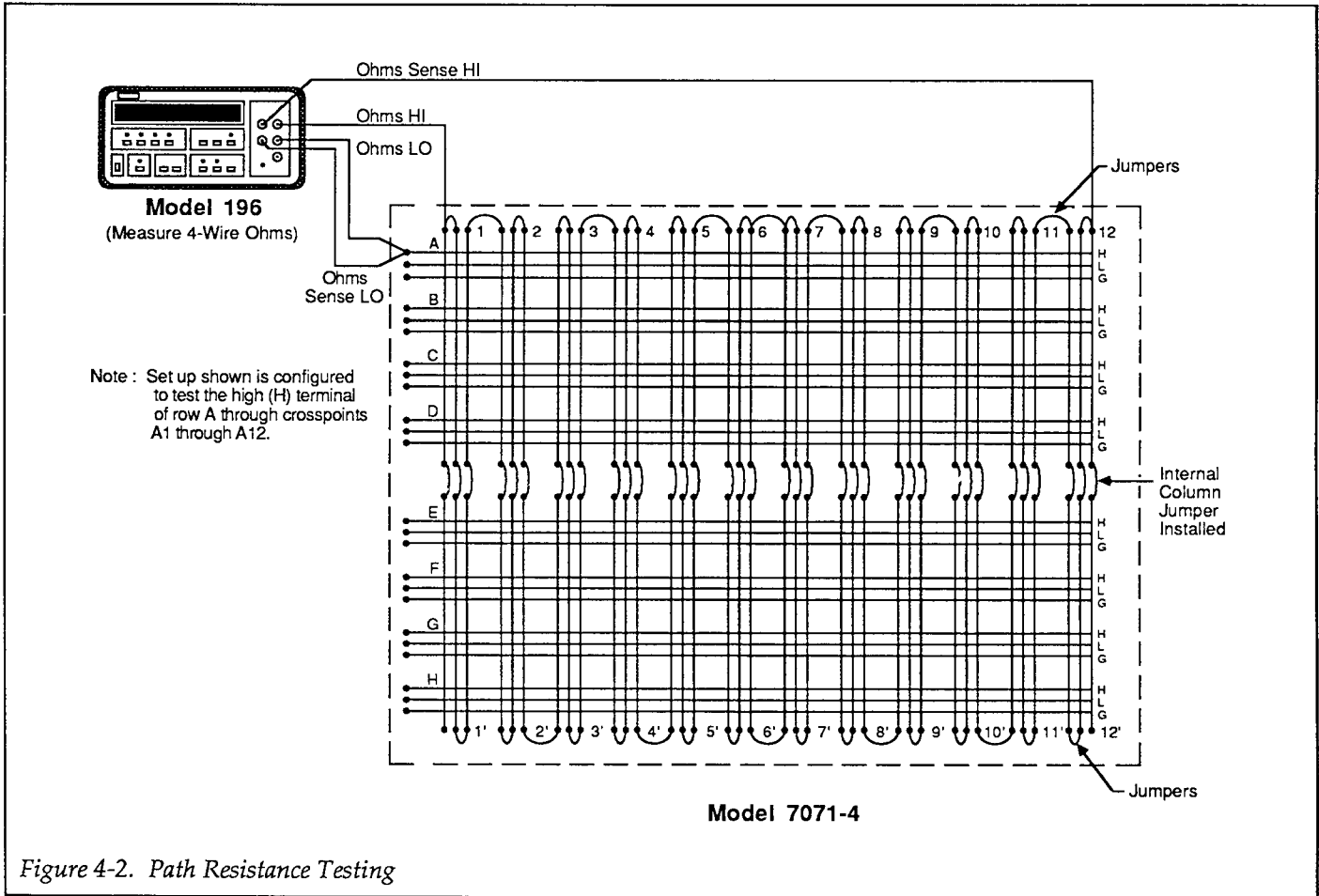

Figure 4-2. Path Resistance Testing

3. Remove the eight quick-disconnect terminal blocks from the PC board of the matrix card. This allows test lead connections to be made at the PC board terminal posts.
4. Place the Model 7071-4 in slot 1 of the Model 707, but do not push it all the way into the mainframe.
5. Set the Model 196 to the 300Ω range and connect four test leads to the OHMS and OHMS SENSE input.
6. Short the four test leads together and zero the Model 196. Leave zero enabled for the entire test.
7. Connect OHMS HI and OHMS SENSE HI of the Model 196 to the common terminal (jumper). It is recommended that the physical connections be made at columns 1 and 12 as shown in Figure 4-2.
8. Connect OHMS LO and OHMS SENSE LO to the high (H) terminal post of ROW A.
9. Feed the test leads through the cable clamp of the matrix card and push the card all the way into the mainframe. Tighten the two spring loaded screws to completely mate the card with the backplane.
10. Turn on the Model 707 and program it to close cross point A1 (ROW A, COLUMN 1), and verify that the resistance of this path is $<1.5\Omega$.
11. Open crosspoint A1, and close A2. Verify that the resistance of this path is $<1.5\Omega$.
12. Open crosspoint A2, and close A3. Verify that the resistance of this path is $<1.5\Omega$.
13. Using the basic procedure of steps 10 through 12, check the resistance of ROW A high (H) terminal paths for COLUMNS 4 through 12 (crosspoints A4 through A12).
14. Turn the Model 707 off and pull the matrix card out of the mainframe approximately six inches in order to gain access to the terminals.
15. Move the OHMS LO and OHMS SENSE LO test leads to the low (L) terminal of ROW A.
16. Repeat steps 9 through 12 to check the low (L) terminal paths of ROW A.

17. Turn the Model 707 off and move the OHMS LO and OHMS SENSE LO test leads to the guard (G) terminal of ROW A.
18. Repeat steps 9 through 12 to check the guard (G) terminal paths of ROW A.
19. Repeat the basic procedure in steps 1 through 18 for ROWS B through H.

4.4 .5 Offset Current Tests

These tests check leakage current between high (H) and low (L) (differential offset current) and from high and low to guard (G) (common mode offset current) of each pathway. In general, these tests are performed by simply measuring the leakage current with an electrometer. In the following procedure, the Model 617 is used to measure leakage current.

Perform the following procedure to check offset current:

1. Turn the Model 707 off if it is on and remove any jumpers attached to the COLUMNS receptacles.
2. Connect the Model 617 to a quick-disconnect terminal block as shown in Figure 4-3. Do not connect the terminal block to the matrix card at this time.
3. Place the matrix card in slot 1 of the Model 707, but do not slide it all the way into the mainframe.
4. On the Model 617, select the 200pA range, and enable zero check and zero correct in that order. Leave zero correct enabled for the entire procedure.
5. Connect the pre-wired terminal block to ROW A of the matrix card.
6. Feed the test leads through the cable clamp of the matrix card and push the card all the way into the mainframe. Tighten the two spring loaded screws to completely mate the card with the backplane.
7. Turn on the Model 707
8. Program the Model 707 to close crosspoint A1.
9. On the Model 617, disable zero check and verify that it is <100pA. This measurement is the leakage current of the pathway.

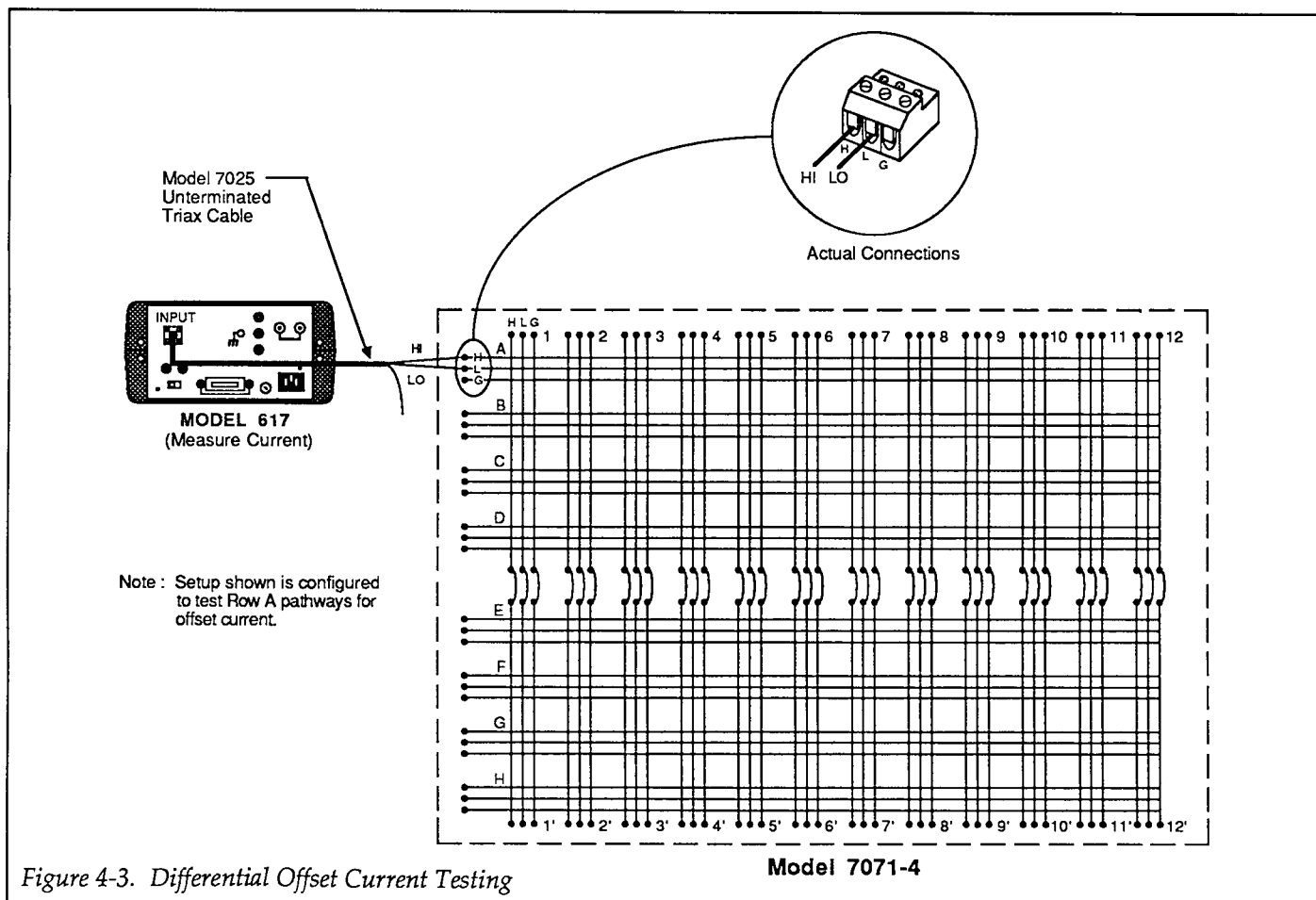

Figure 4-3. Differential Offset Current Testing

10. On the Model 617, enable zero check and on the Model 707, open crosspoint A1.
11. Repeat the basic procedure in steps 8 through 10 to check the rest of the pathways (crosspoints A2 through A12) of the row.
12. Turn off the Model 707 and slide out the matrix card far enough to gain access to the pre-wired terminal block.
13. Move the terminal block down to ROW B and repeat the basic procedure in steps 6 through 11 to check crosspoints B1 through B12.
14. Repeat the basic procedure in steps 12 and 13 for the remaining rows (ROWS C through H).
15. Turn off the Model 707, and slide the matrix card out far enough to gain access to the pre-wired terminal block.
16. Rewire the terminal block as shown in Figure 4-4.
17. Repeat steps 5 through 14 to check common mode offset current.

4.4 .6 Contact Potential Tests

These tests check the EMF generated by each relay contact pair (H and L) for each pathway. The tests simply consist of using a nanovoltmeter (Model 181) to measure the contact potential.

Perform the following procedure to check contact potential of each path:

1. Turn the Model 707 off if it is on.
2. Using 12 prepared jumper wires, short high to low of all 12 matrix columns at the COLUMNS receptacle as shown in Figure 4-5. Terminal identification is provided in Figure 2-13. Notice that that the wiring side of the COLUMNS receptacle is shown. Thus,

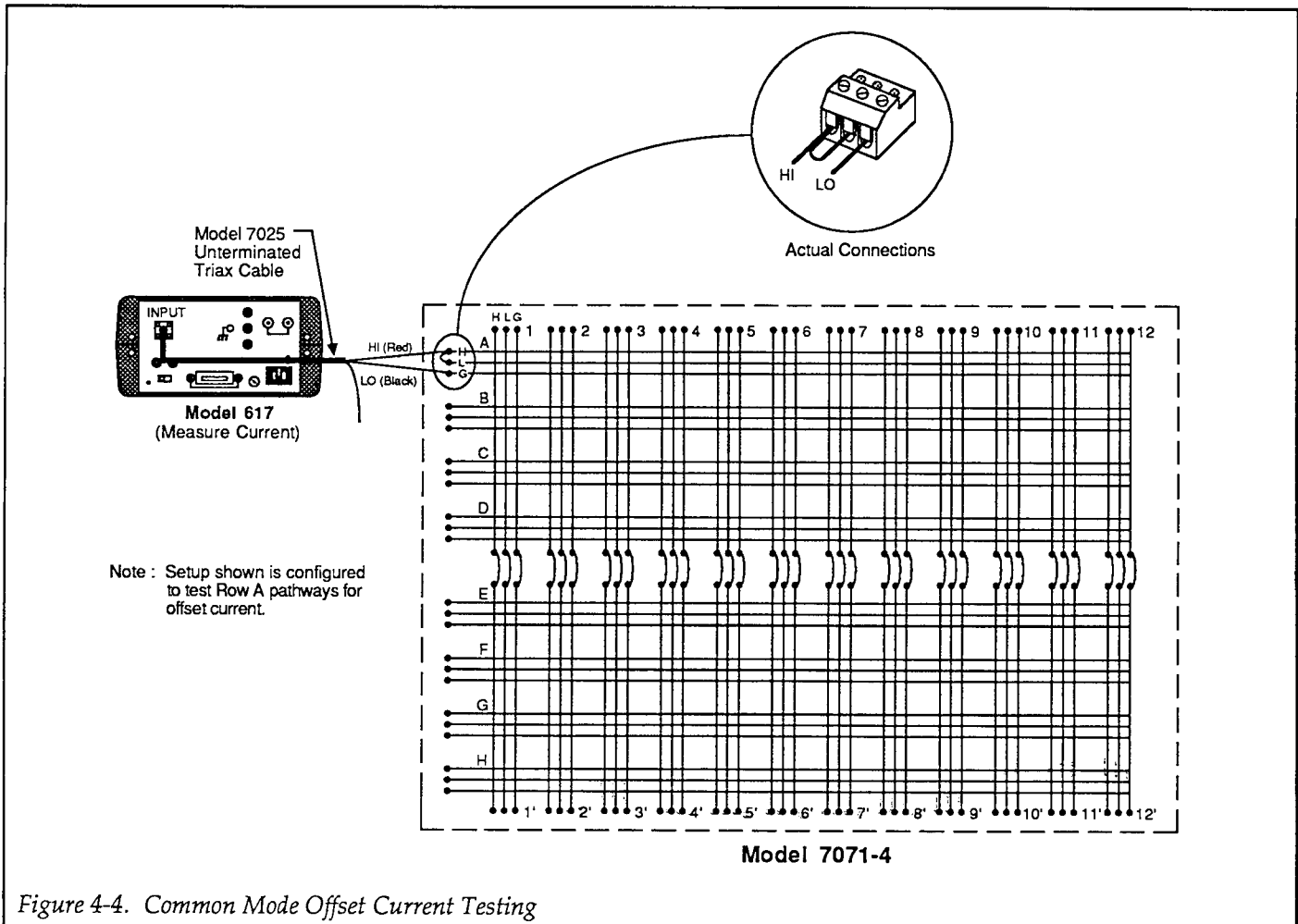

Figure 4-4. Common Mode Offset Current Testing

the contact side of the receptacle is the mirror image of that drawing.

3. Set the Model 181 to the 2mV range, short the input leads and press ZERO to null out internal offset. Leave zero enabled for the entire procedure.
4. Connect the Model 181 to a quick-disconnect terminal block as shown in the illustration caption of Figure 4-5. Do not connect the terminal block to the matrix card at this time.
5. Place the matrix card in slot 1 of the Model 707, but do not slide it all the way into the mainframe.
6. Connect the pre-wired terminal block to ROW A of the matrix card.
7. Feed the test leads through the cable clamp of the matrix card and push the card all the way into the mainframe. Tighten the two spring loaded screws to completely mate the card with the backplane.
8. Turn on the Model 707
9. Program the Model 707 to close crosspoint A1.
10. Verify that the reading on the Model 181 is $<5\mu\text{V}$ for one minute. After one minute, thermals could reach

a maximum of $10\mu\text{V}$. This measurement is the contact potential of the pathway.

11. From the Model 707, open crosspoint A1.
12. Repeat the basic procedure in steps 9 through 11 to check the rest of the pathways (crosspoints A2 through A12) of the row.
13. Turn off the Model 707 and slide out the matrix card far enough to gain access to the pre-wired terminal block.
14. Move the terminal block down to ROW B and repeat the basic procedure in steps 7 through 12 to check crosspoints B1 through B12.
15. Repeat the basic procedure in steps 13 and 14 for the remaining rows (ROWS C through H).

4.4 .7 Path Isolation Tests

These tests check the leakage resistance (isolation) between adjacent paths. A path is defined as the high (H),

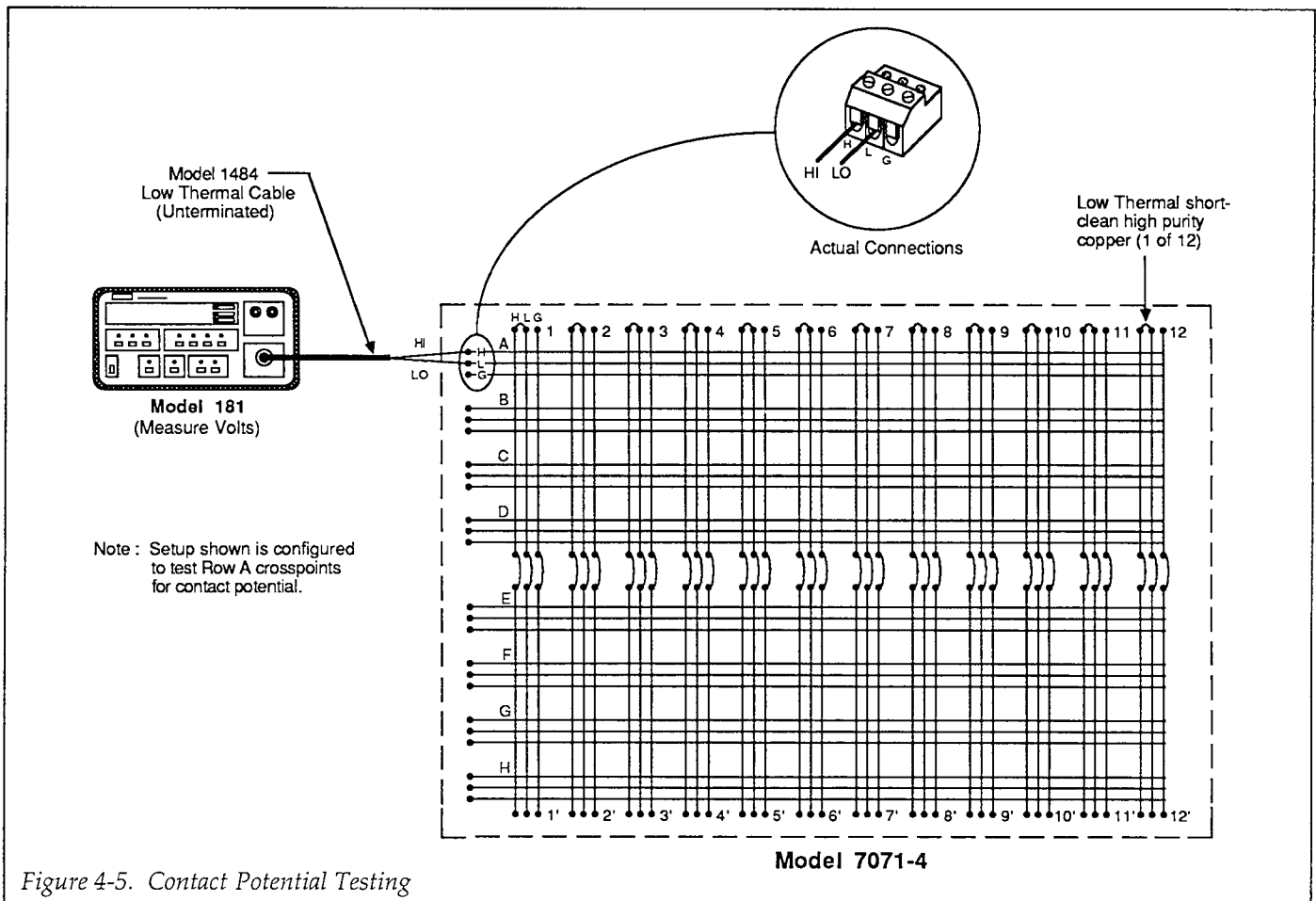

Figure 4-5. Contact Potential Testing

low (L), guard (G) circuit from a row to a column that results by closing a particular crosspoint. In general, the test is performed by applying a voltage (+100V) across two adjacent paths and then measuring the leakage current across the paths. The isolation resistance is then calculated as $R = V/I$. In the following procedure, the Model 617 functions as both a voltage source and an ammeter. In the V/I function, the Model 617 internally calculates the resistance from the known voltage and current levels and displays the resistive value.

NOTE

Refer to Figure 4-6 for the following procedure.

1. Turn the Model 707 off if it is on and remove any jumpers installed at the COLUMNS receptacles.
2. Connect the Model 617 to two quick-disconnect terminal blocks as shown in the illustration. Also, be sure to install the three jumper wires as shown. Do

not connect the terminal blocks to the matrix card at this time.

3. On the matrix card, unplug all row terminal blocks from the PC board.
4. Place the matrix card in slot 1 of the Model 707, but do not slide it all the way into the mainframe.

WARNING

The following steps use high voltage (100V). Be sure to remove power from the circuit before making connection changes.

5. On the Model 617, select the 2pA range, and enable zero check and zero correct in that order. Leave zero correct enabled for the entire procedure.
6. Connect the two pre-wired terminal blocks to ROWS A and B of the matrix card.
7. Feed the test leads through the cable clamp of the matrix card and push the card all the way into the mainframe. Tighten the two spring loaded screws to completely mate the card with the backplane.

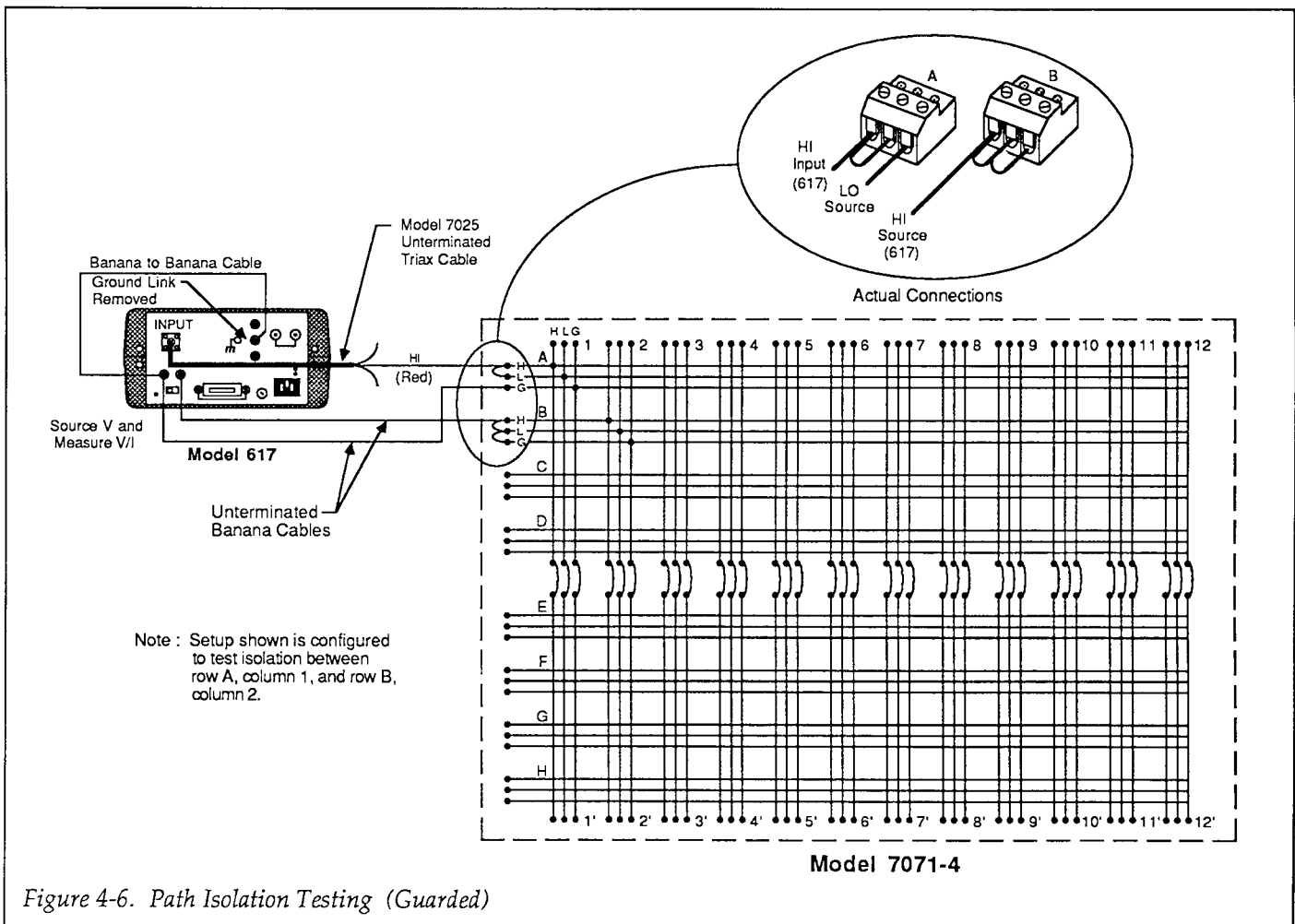

Figure 4-6. Path Isolation Testing (Guarded)

8. On the Model 617, select the 20pA range and release zero check.
9. On the Model 617, press suppress to cancel offset current and then enable zero check.
10. On the Model 617, set the voltage source for +100V, and select the 20nA current range. Make sure the voltage source is in standby.
11. Place the Model 617 in the V/I measurement function by pressing SHIFT OHMS.
12. Turn on the Model 707, and program it to close crosspoints A1 (ROW A, COLUMN 1) and B2 (ROW B, COLUMN 2).
13. On the Model 617, disable zero check and press OPERATE to source +100V.
14. After allowing the reading on the Model 617 to settle, verify that it is >10GΩ. This measurement is the leakage resistance (isolation) between ROW A, COLUMN 1 and ROW B, COLUMN 2.
15. Place the Model 617 in standby and enable zero check.
16. Turn off the Model 707, and slide the matrix card approximately six inches out of the mainframe to gain access to the terminal blocks.
17. Move the two pre-wired terminal blocks down one row so that they are located on ROWS B and C.
18. Reinstall the matrix card and turn on the Model 707.
19. Program the Model 707 to close crosspoints B2 and C3.
20. On the Model 617, disable zero check and press OPERATE to source +100V.
21. After allowing the reading on the Model 617 to settle, verify that it is >10GΩ.
22. Using Table 4-2 as a guide, repeat the basic procedure of steps 15 through 21 for the rest of the path pairs (test numbers 3 through 11 in the table).

4.4 .8 Differential and Common Mode Isolation Tests

These tests check the leakage resistance (isolation) between high (H) and low (L) (differential), and from high and low to guard (G) (common mode) of every row and column. In general, the test is performed by applying a voltage (100V) across the terminals and then measuring the leakage current. The isolation resistance is then calculated as $R = V/I$. In the following procedure, the Model 617 functions as a voltage source and an ammeter. In the V/I function, the Model 617 internally calculates the resistance from the known voltage and current levels and displays the resistance value.

1. Turn the Model 707 off if it is on and remove any jumpers installed at the COLUMNS receptacles.
2. Connect the Model 617 to a quick-disconnect terminal block as shown in Figure 4-7. Do not connect the terminal blocks to the matrix card at this time.
3. Place the matrix card in slot 1 of the Model 707, but do not slide it all the way into the mainframe.

WARNING

The following steps use high voltage (100V).
Be sure to remove power from the circuit before making connection changes.

4. On the Model 617, select the 2pA range, and enable zero check and zero correct in that order. Leave zero correct enabled for the entire procedure.

Table 4-2. Path Isolation Tests

Test No.	Path Isolation	Test Equipment Location	Crosspoints Closed
1	Row A, col 1 to Row B, col 2	Row A and Row B	A1 and B2
2	Row B, col 2 to Row C, col 3	Row B and Row C	B2 and C3
3	Row C, col 3 to Row D, col 4	Row C and Row D	C3 and D4
4	Row D, col 4 to Row E, col 5	Row D and Row E	D4 and E5
5	Row E, col 5 to Row F, col 6	Row E and Row F	E5 and F6
6	Row F, col 6 to Row G, col 7	Row F and Row G	F6 and G7
7	Row G, col 7 to Row H, col 8	Row G and Row H	G7 and H8
8	Row G, col 8 to Row H, col 9	Row G and Row H	G8 and H9
9	Row G, col 9 to Row H, col 10	Row G and Row H	G9 and H10
10	Row G, col 10 to Row H, col 11	Row G and Row H	G10 and H11
11	Row G, col 11 to Row H, col 12	Row G and Row H	G11 and H12

5. On the Model 617, set the voltage source for +100V, and select the 200nA current range. Make sure the voltage source is still in standby.
6. Place the Model 617 in the V/I measurement function by pressing SHIFT OHMS.
7. With the Model 617 in standby, connect the pre-wired terminal block to ROW A of the matrix card.
8. Feed the test leads through the cable clamp of the matrix card and push the card all the way into the mainframe. Tighten the two spring loaded screws to completely mate the card with the backplane.
9. Turn on the Model 707, but do not program any crosspoints to close. All crosspoints must be open.
10. On the Model 617, disable zero check and press OPERATE to source 100V.
11. After allowing the reading on the Model 617 to settle, verify that it is $>1G\Omega$. This measurement is the leakage resistance (isolation) of ROW A.
12. Place the Model 617 in standby and enable zero check.
13. Program the Model 707 to close crosspoint A1.
14. On the Model 617, disable zero check and press OPERATE to source +100V.
15. After allowing the reading on the Model 617 to settle, verify that it is also $>1G\Omega$. This measurement checks the isolation of COLUMN 1.
16. Using Table 4-3 as a guide, repeat the basic procedure of steps 12 through 15 for the rest of the columns and rows (test numbers 3 through 20 of the table).
17. Turn the Model 707 off and slide the matrix card out of the mainframe far enough to gain access to the

- pre-wired terminal block.
18. Remove the terminal block from the matrix card and rewire the it as shown in Figure 4-8.
19. Repeat steps 7 through 16 to check common mode isolation.

Table 4-3. Differential and Common Mode Isolation Test

Test No.	Differential or Common Mode Test	Crosspoints Closed
1	ROW A	None
2	COLUMN 1	A1
3	COLUMN2	A2
4	COLUMN3	A3
5	COLUMN4	A4
6	COLUMN5	A5
7	COLUMN6	A6
8	COLUMN7	A7
9	COLUMN8	A8
10	COLUMN9	A9
11	COLUMN10	A10
12	COLUMN11	A11
13	COLUMN12	A12
14	ROW B	A1 and B1
15	ROW C	A1 and C1
16	ROW D	A1 and D1
17	ROW E	A1 and E1
18	ROW F	A1 and F1
19	ROW G	A1 and G1
20	ROW H	A1 and H1

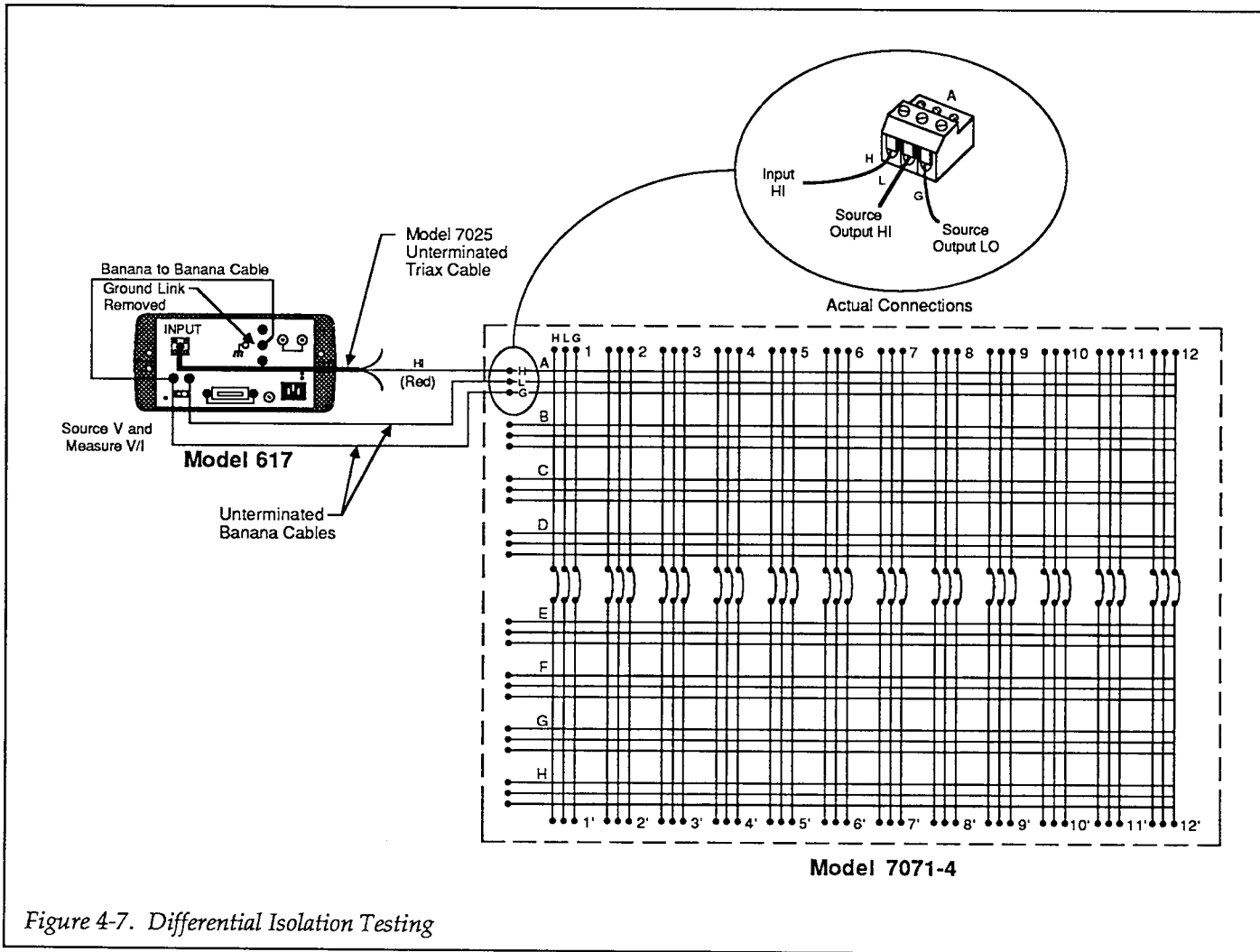

Figure 4-7. Differential Isolation Testing

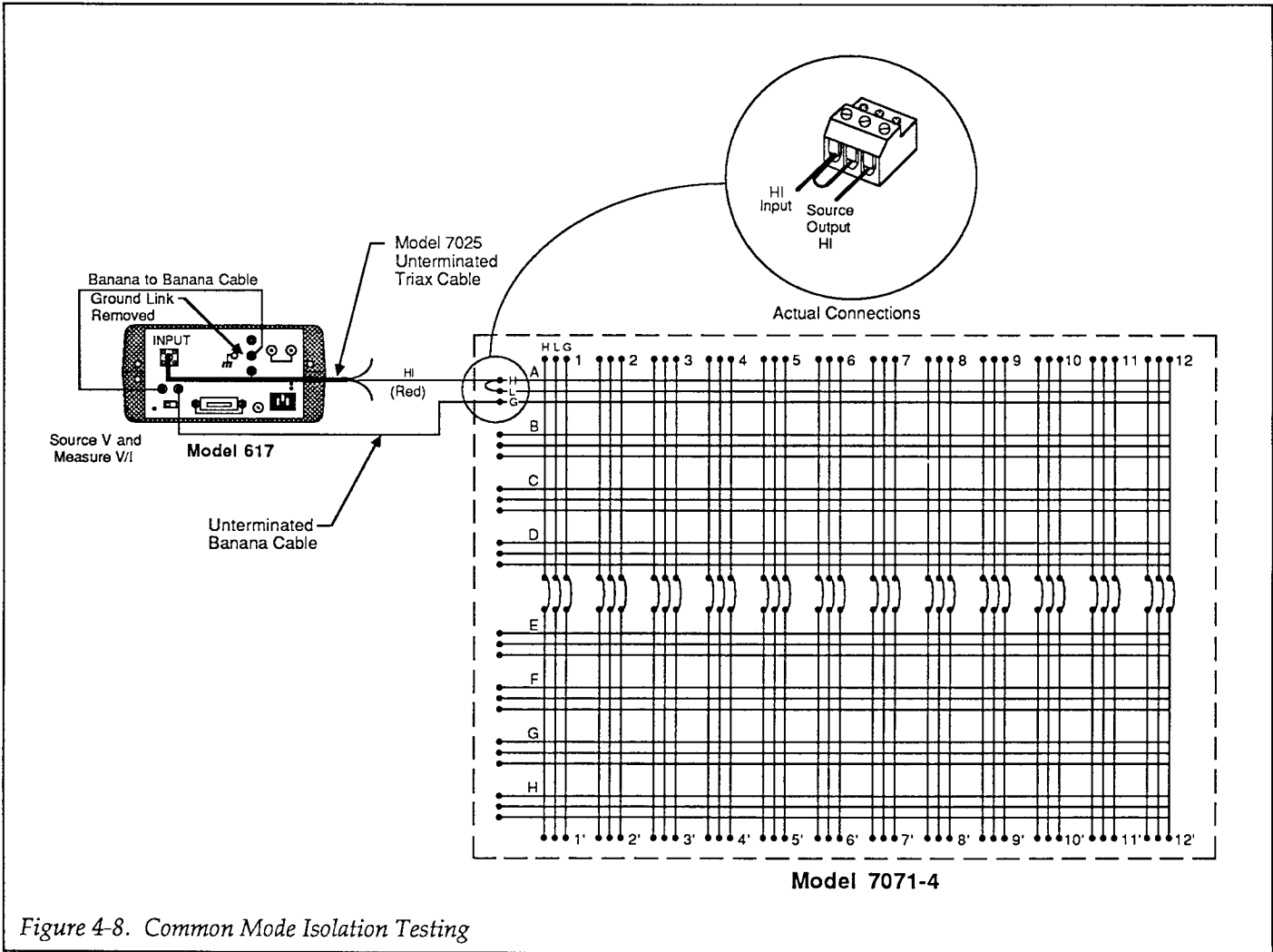

Figure 4-8. Common Mode Isolation Testing

4.5 PRINCIPLES OF OPERATION

The paragraphs below discuss the basic operating principles for the Model 7071-4 and can be used as an aid in troubleshooting the matrix card. The schematic drawing of the matrix card is shown on drawing number 7071-4-106, located at the end of Section 5.

4.5.1 Card Identification

Identification coding and a matrix configuration table is stored in an erasable programmable read-only memory (EPROM). This information is sent to the Model 707 so that it "knows" which type of matrix card is installed in that particular mainframe slot. This enables the Model 707 to send valid configuration data to the matrix card.

On power up, control line CARDSEL goes low turning on the EPROM (U27). That control line, as well as the other control lines from the Model 707, are buffered by U44. Lines CLK, NEXT ADDR and CLR ADDR along with counter U45 control the task of loading data from the EPROM into the parallel shift register (U43). Data sent from U47 to the Model 707 via the IDDATA line is strobed by the CLK control line. The timing diagram in Figure 4-9 shows the first byte of identification data dur-

ing the transfer sequence. For subsequent bytes, the CLRADDR line stays low.

4.5.2 Switching Circuitry

Matrix configuration data is sent from the Model 707 via the RELAY DATA control line and is serially loaded into the 12 shift registers (U30 through U41). The matrix card relays configure accordingly when the registers receive the STROBE signal from the Model 707. A relay is energized when a register output is low (connected to digital common). A register output is low when a "high" data bit is clocked into it (i.e. inverting drivers).

4.5.3 Power Up Safeguard

To prevent relays from inadvertently energizing and causing possible damage during power up, a safeguard circuit has been incorporated into the design. The protection circuit is comprised of a dual NAND gate (U42) configured as a SET/RESET flip-flop and an RC network (R1, C20 and CR1). The time constant of the RC network keeps the the output of the NAND gate high during the power up sequence. This high signal is applied to the OEN input of the shift registers keeping the relays de-energized. After the capacitor of the RC network charges, a STROBE signal will then force the output of the NAND gate low allowing configured relays to energize.

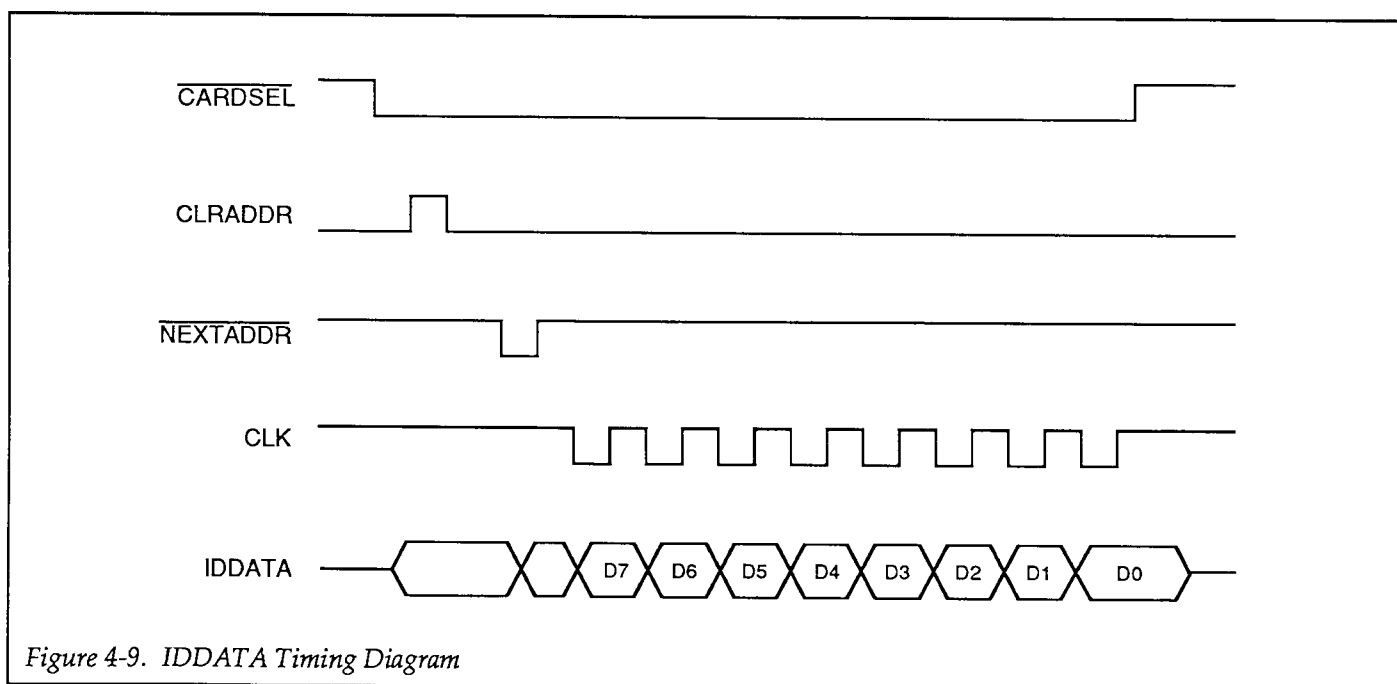

Figure 4-9. IDDATA Timing Diagram

4.6 SPECIAL HANDLING OF STATIC-SENSITIVE DEVICES

CMOS and other high-impedance devices are subject to possible static discharge damage because of the high-impedance levels involved. The following precautions pertain specifically to static-sensitive devices. However, since many devices in the Model 7071-4 are static-sensitive, it is recommended that they all be treated as static-sensitive.

1. Such devices should be transported and handled only in containers specially designed to prevent or dissipate static build-up. Typically, these devices will be received in anti-static containers made of plastic or foam. Keep these parts in their original containers until ready for installation.
2. Remove the devices from their protective containers only at a properly grounded work station. Also ground yourself with a suitable wrist strap while working with these devices.
3. Handle the devices only by the body; do not touch the pins.
4. Any printed circuit board into which the device is to be inserted must first be grounded to the bench or table.
5. Use only anti-static type de-soldering tools and grounded-tip soldering irons.

4.7 TROUBLESHOOTING

The Keithley Model 7070 Universal Adapter Card is an extender card that allows access to circuit components of the Model 7071-4 during troubleshooting. Also, Figure 4-10, which provides receptacle contact identification, is included as a troubleshooting aid.

4.7.1 Recommended Equipment

Table 4-4 summarizes the equipment necessary for general troubleshooting.

Table 4-4. Recommended Troubleshooting Equipment

Description	Application
DMM (Keithley 196)	Measure dc voltage
Dual-trace, triggered sweep oscilloscope, dc to 50MHz	Check clock and logic pulses
Extender card (Keithley 7070)	Allow circuit access

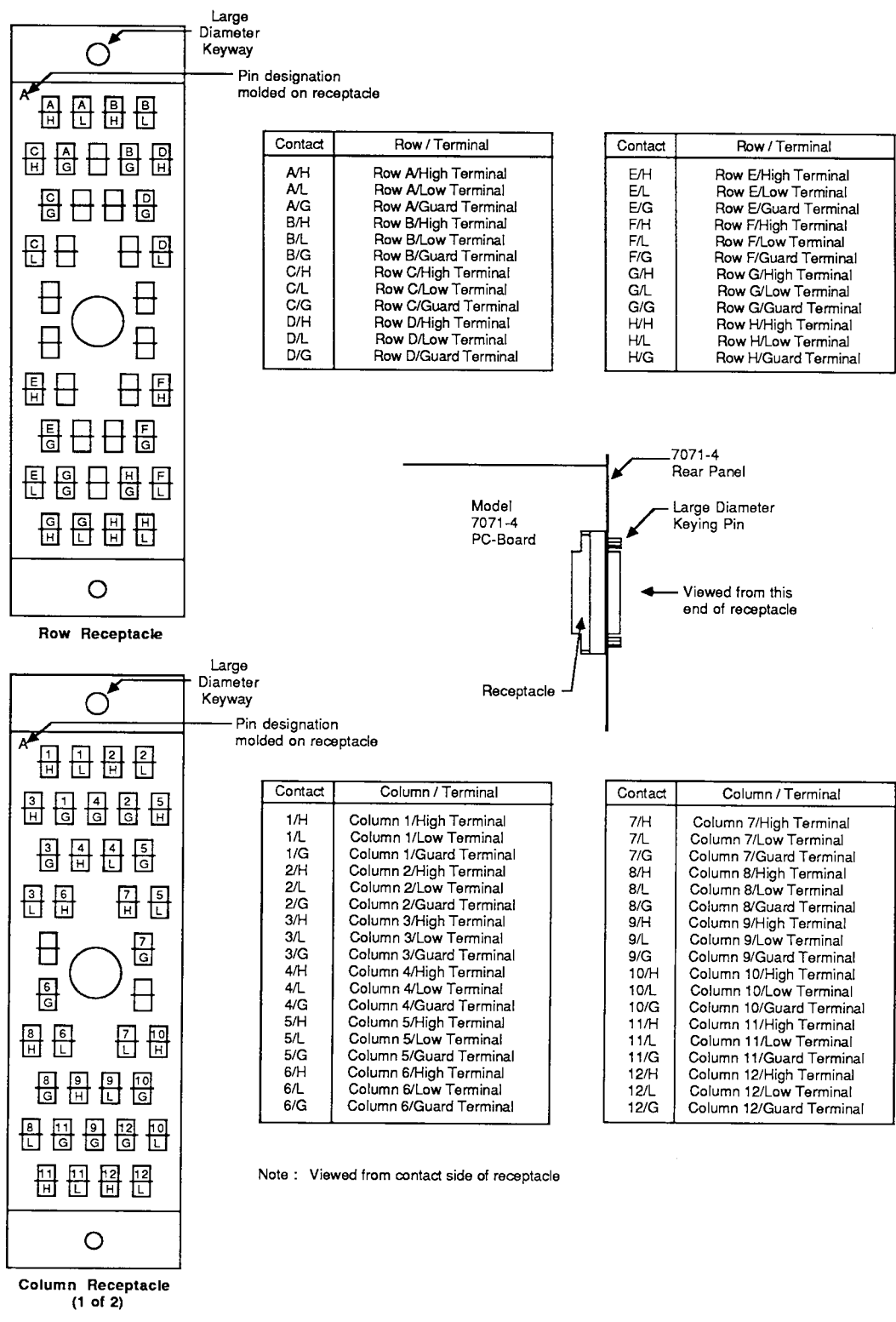

Figure 4-10. Receptacle Contact Identification

4.7 .2 Troubleshooting Procedure

In order to service the matrix card, it may be necessary to remove the rear shield. Referring to Figure 4-11, perform the following procedure to remove and reinstall the rear shield:

1. Disconnect the jumper wire from the matrix card chassis. The wire is secured to the matrix card with a screw.
2. The rear shield is secured to the matrix card by eight standoffs. Carefully slide the rear shield upward until the eight standoffs align with the large clearance holes in the shield and remove the shield.
3. To reinstall the shield, reverse the above procedure. Make sure the metal side of the shield is facing outward.

CAUTION

Failure to observe the following precautions could result in damage not covered by the warranty:

1. The shield must be installed such that the metal side is facing away from the matrix card. Backward installation will cause PC

board connections to short out against the metal shield.

2. The jumper wire must be connected as shown in order to provide circuit protection from static discharge

Table 4-5 outlines the troubleshooting procedure for the matrix card.

CAUTION

Contamination will degrade the performance of the matrix card. To avoid contamination, always grasp the card by the handle and side edges. Do not touch the edge connectors of the card, and do not touch the board surfaces or components. On "rack and panel" connectors and quick-disconnect terminal blocks, do not touch areas adjacent to the electrical contacts.

CAUTION

If removing relays from the PC-board, care must be taken to prevent traces from being ripped off the board. Using a solder sucker, make sure all solder is removed. Each relay pin must move freely in the flow-through hole. Also, make sure there are no burrs on the ends of the relay pins.

Table 4-5. Troubleshooting Summary*

Step	Items/Component	Comment	Required Condition
1	TP1	+6V supply	+6V dc
2	TP3	+5V supply	+5V dc
3	TP5	CLR ADDR line**	High logic pulse at beginning of each card identification byte transfer sequence (upon power up).
4	TP4	<u>NEXT ADDR</u> line**	Low logic pulse before each byte transfer.
5	TP9	Clk line	1.79MHz clock
6	TP6	IDData line**	Card identification logic pulse train (on power up).
7	TP10	Power up safeguard	Remains high during power up.
8	TP8	RELAY DATA line	Logic pulse train to load relay configuration registers.
9	TP7	STROBE line	High logic pulse to strobe relay configuration registers.
10	U30 through U41 pins 11 through 18	Relay drivers	+6V for open crosspoints ≈ 0V for closed crosspoints.

*All measurements referenced to digital common (TP2)

**See Figure 4-9

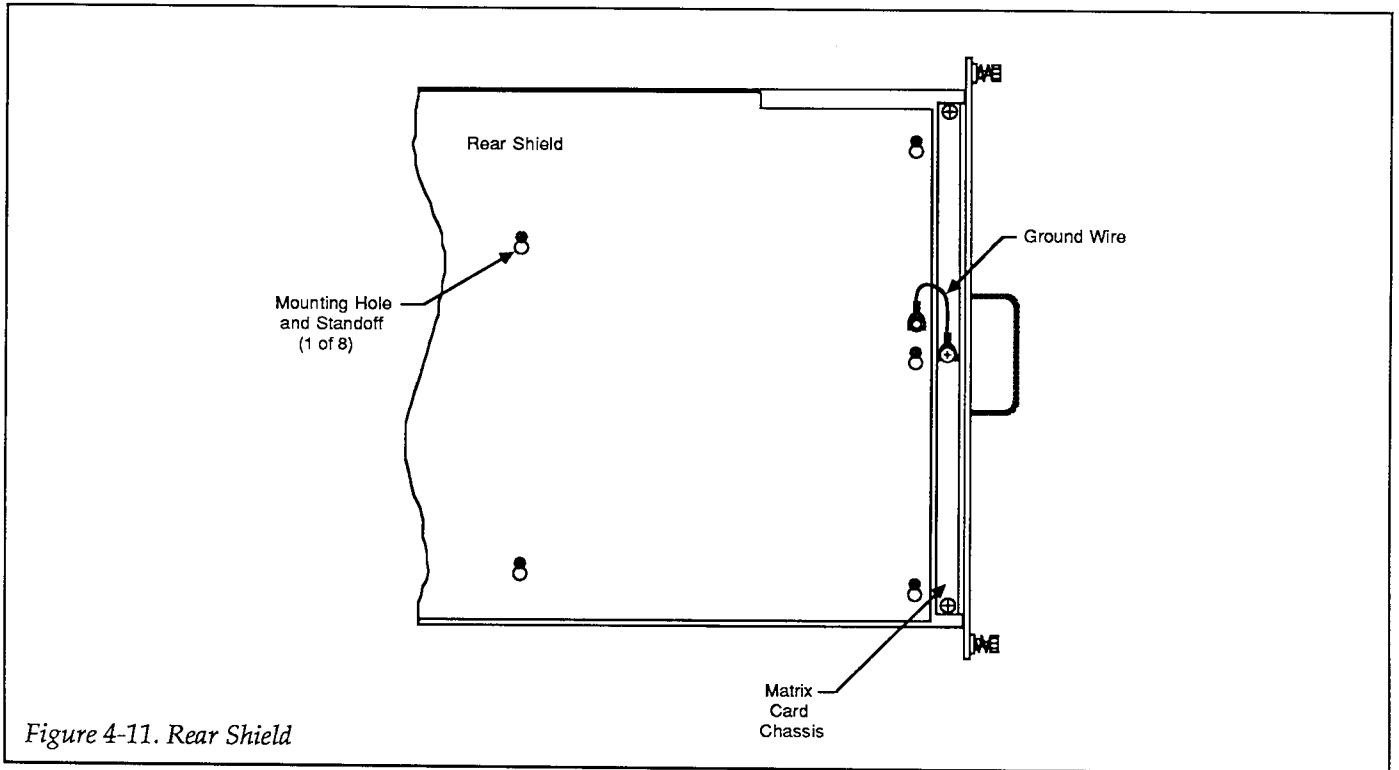

Figure 4-11. Rear Shield

SECTION 5

Replaceable Parts

5.1 INTRODUCTION

This section contains a list of replaceable electrical and mechanical parts for the Model 7071-4, as well as a component layout drawing and schematic diagram of the matrix card.

5.2 PARTS LIST

Electrical parts are listed in order of circuit designation in Table 5-1. Table 5-2 summarizes miscellaneous parts.

5.3 ORDERING INFORMATION

To place an order, or to obtain information concerning replacement parts, contact your Keithley representative or the factory (see inside front cover for addresses). When ordering parts, be sure to include the following information:

1. Matrix card model number (7071-4)
2. Card serial number
3. Part description

4. Circuit description, if applicable
5. Keithley part number

5.4 FACTORY SERVICE

If the matrix card is to be returned to Keithley Instruments for repair, perform the following:

1. Complete the service form at the back of this manual and include it with the card.
2. Carefully pack the card in the original packing carton.
3. Write ATTENTION REPAIR DEPT on the shipping label.

Note: It is not necessary to return the matrix mainframe with the card.

5.5 COMPONENT LAYOUT AND SCHEMATIC DIAGRAM

Figure 5-1 shows a component layout of the Model 7071-4, while Figure 5-2 shows a schematic diagram.

Table 5-1 Model 7071-4 Parts List

CIRCUIT DESIG.	DESCRIPTION	KEITHLEY PART NO.
C18,C19	CAP,10uF,-20+100%,25V,ALUM ELEC	C-314-10
C20	CAP,47UF,10%,16V,ALUM ELEC	C-321-47
C21,C22	CAP,.01uF,20%,50V,CERAMIC	C-237-.01
C23..C34		
C35,C36	CAP,270pF,20%,100V,CERAMIC/FERRITE	C-386-270P
C37	CAP,.01uF,10%,1000V,CERAMIC	C-64-.01
C6..C8,C16,C17,	CAP,.1uF,20%,50V,CERAMIC	C-365-.1
CR1	DIODE,SILICON,1N4148 (DO-35)	RF-28
CR2	DIODE,SCHOTTKY,1N5711	RF-69
FOR U27	SOCKET	SO-69
J1..J20	CONN,3 PIN	CS-570-3
J21,J22	SOCKET,CONNECTOR	CS-593
K1..K96	RELAY	RL-67
R1	RES,47K,5%,1/4W,COMPOSITION OR FILM	R-76-47K
R2	RES,10K,5%,1/4W,COMPOSITION OR FILM	R-76-10K
R3	RES,120K,5%,1/4W,COMPOSITION OR FILM	R-76-120K
R4	RES,11K,5%,1/4W,COMPOSITION OR FILM	R-76-11K
R5	RES,910,5%,1/4W,COMPOSITION OR FILM	R-76-910
R6	RES,200,5%,1/4W,COMPOSITION OR FILM	R-76-200
TP1..TP10	CONN,TEST POINT	CS-553
U27	PROGRAM	7071-4-800
U30..U41	IC,8-BIT SERIAL-IN/LTCH DRIVE,UCN-5841A	IC-536
U42	IC,QUAD 2 INPUT NAND,74HCT00	IC-399
U43	IC,8 BIT PARALLEL TO SERIAL,74HCT165	IC-548
U44	IC,OCTAL BUFFER/LINE DRIVER,74HCT244	IC-483
U45	IC,12 STAGE BINARY COUNTER,74HCT4040	IC-545
W1	STIFFENER,BOARD	J-16

Table 5-2. Model 7071-4, Miscellaneous Parts List

QUANTITY	DESCRIPTION	KEITHLEY PART NO.
2	UPPER CLAMP ASSEMBLY	-
2	UPPER CLAMP	7071-305
2	RUBBER STRIP	7071-307-1
2	LOWER CLAMP ASSEMBLY	-
2	LOWER CLAMP	7071-306
2	RUBBER STRIP	7071-307-1
1	HANDLE	HH-33-1
1	CONNECTOR STRIP	CS-576-24
1	SOCKET (FOR U27)	SO-69
1	SHIELD, REAR	7071-311
8	STANDOFFS	7071-310

001-P-120C.DN

LTR	ECO NO.	REVISION	ENG.	DATE
B	12944	RELEASED	SP	8/12/68
C	13253	REVISED	SP	2/10/69
D	13157	ORDINOR WAS REV. C	SP	10/22/68
E	18179	ORDINOR WAS REV. D	SP	12/21/68

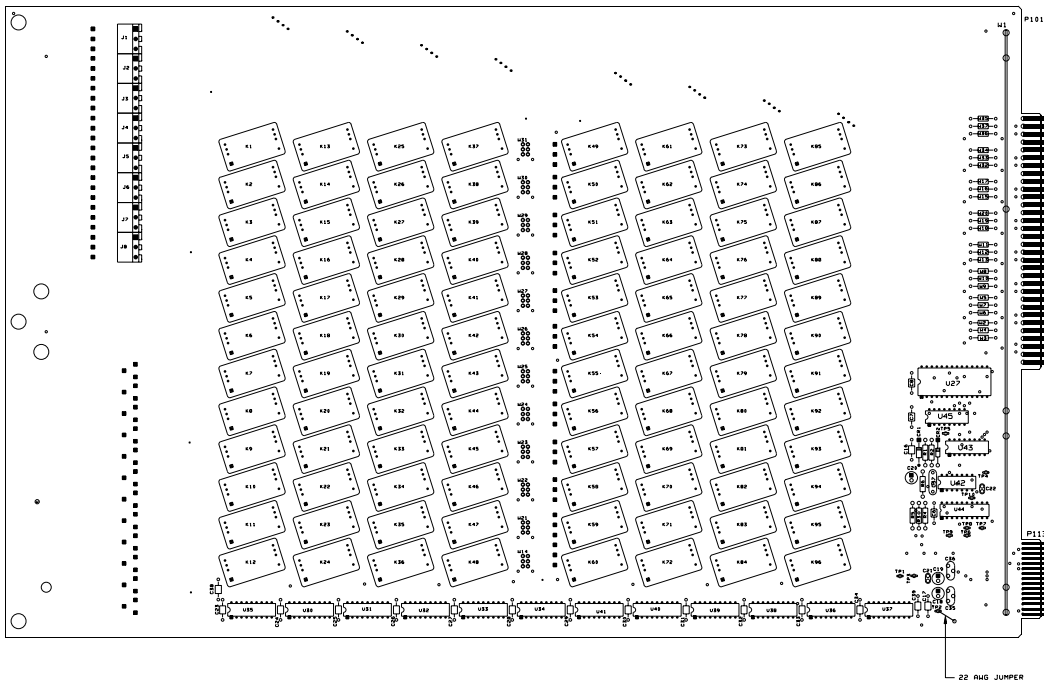

NOTE:
FOR COMPONENT INFORMATION,
REFER TO BILL OF MATERIAL.
(7071-4-000-00).

DO NOT SCALE THIS DRAWING		UNLESS SPECIFIED OTHERWISE	DATE 8-8-68	SCALE 1:1	TITLE COMPONENT LAYOUT,
REVISED BY	DATE	REV. NO.	BY	DATE	GENERAL PURPOSE MATRIX CARD
RETHELYE	ACTELBYE INSTRUMENTS INC.	NOV. 1965	PAR. 23140	MATERIAL	DWG. NO. 7071-4-100
SURFACE MAX. 0.5		FINISH			

7071-4	GENERAL PURPOSE MATRIX CARD
7071-4-100	COMPONENT LAYOUT

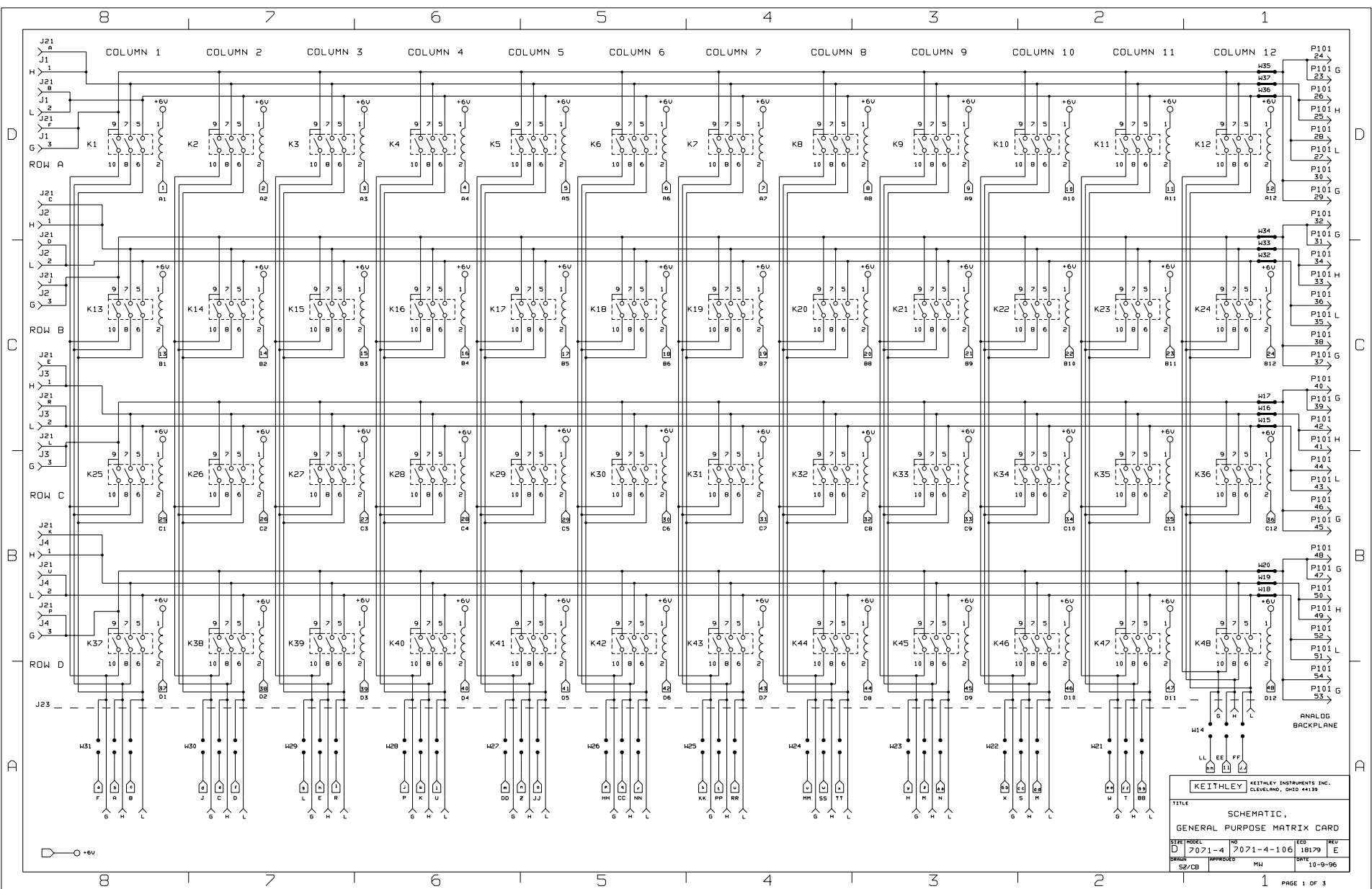

KEITHLEY KEITHLEY INSTRUMENTS INC.
 CLEVELAND, OHIO 44139

1314c
SCHEMATIC,
GENERAL PURPOSE MATRIX CARD

PART MODEL: 7071-4	REV: 1B179	REV: E
DESIGNED: SZ/CB	APPROVED: MH	DATE: 10-9-96

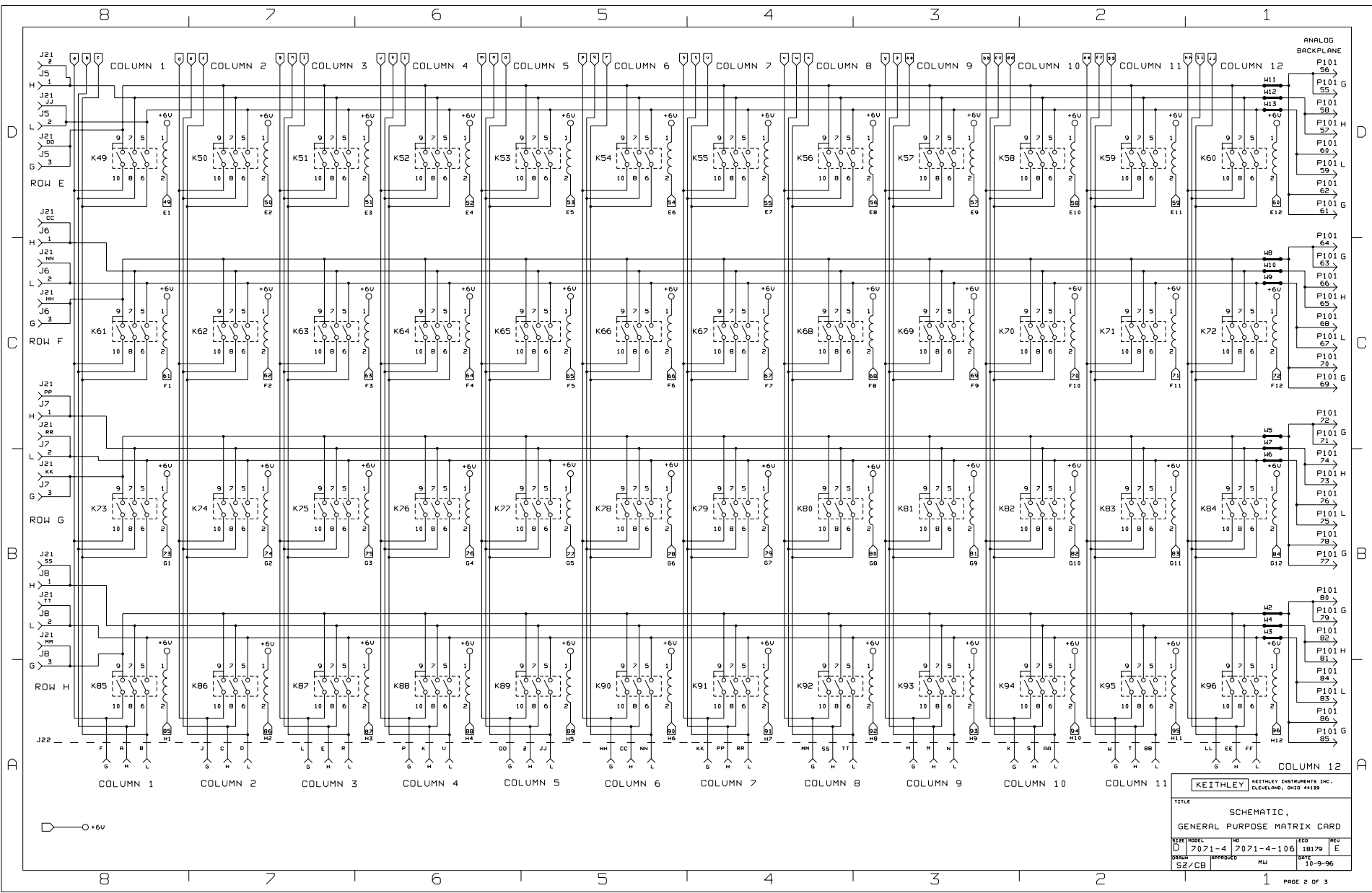

KEITHLEY KEITHLEY INSTRUMENTS INC.
 CLEVELAND, OHIO 44139

TITLE
SCHEMATIC,
GENERAL PURPOSE MATRIX CARD

REV#	MODEL	REV	ECO	REV
D	7071-4	7071-4-106	18179	E
DRWG	APPROVED	MW	DATE	10-9-96
CS/CB				

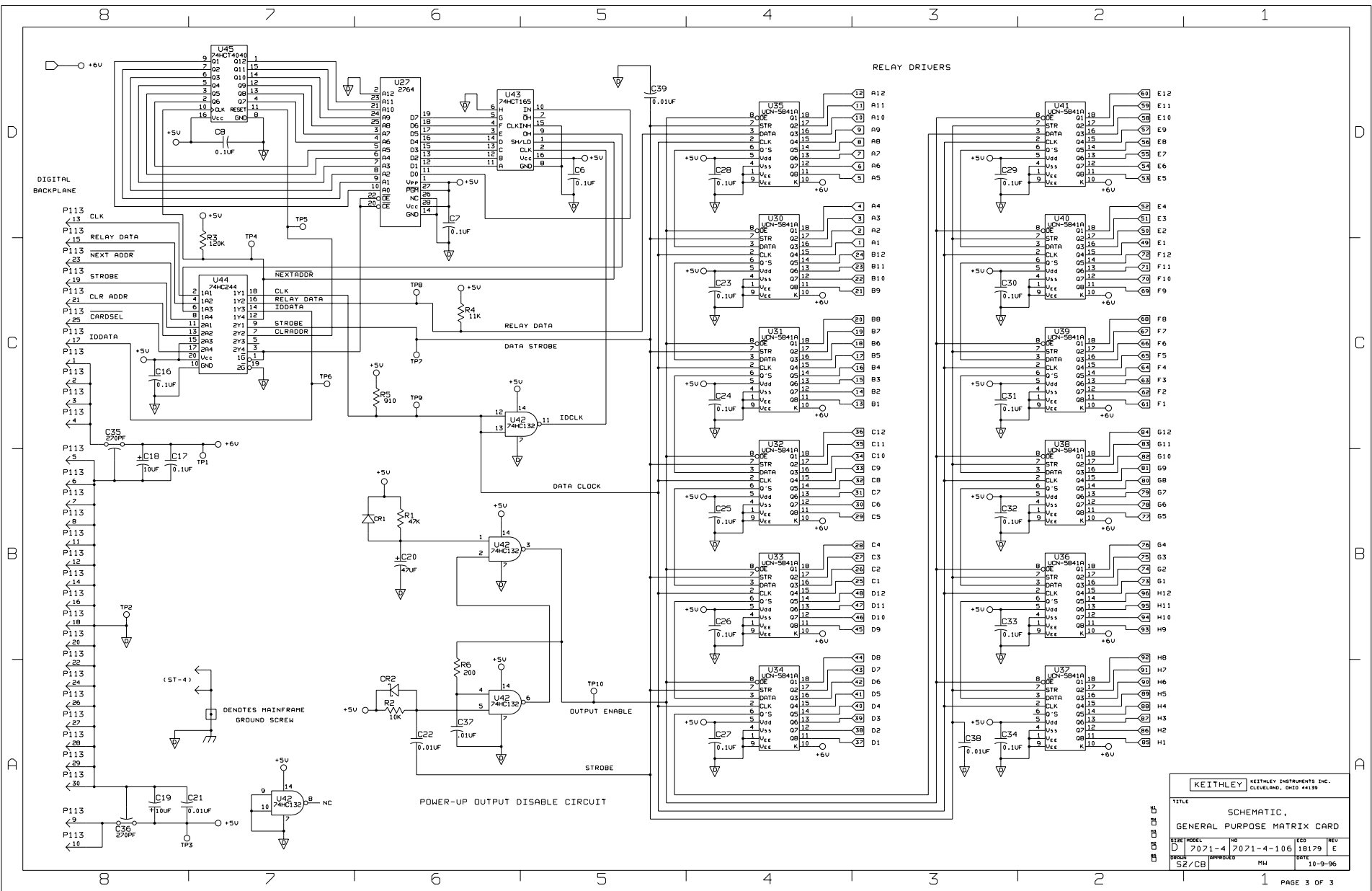

KEITHLEY		KEITHLEY INSTRUMENTS INC.	
		CLEVELAND, OHIO 44139	
TITLE			
SCHEMATIC,			
GENERAL PURPOSE MATRIX CARD			
SIZE	MODEL	REV	REV
D	7071-4	106	18179
DATE	APPROVED	DATE	DATE
S2/CB		MJ	10-9-96



Service Form

Model No. _____ Serial No. _____ Date _____

Name and Telephone No. _____

Company _____

List all control settings, describe problem and check boxes that apply to problem. _____

- | | | |
|--|--|--|
| <input type="checkbox"/> Intermittent | <input type="checkbox"/> Analog output follows display | <input type="checkbox"/> Particular range or function bad; specify |
| <input type="checkbox"/> IEEE failure | <input type="checkbox"/> Obvious problem on power-up | <input type="checkbox"/> Batteries and fuses are OK |
| <input type="checkbox"/> Front panel operational | <input type="checkbox"/> All ranges or functions are bad | <input type="checkbox"/> Checked all cables |

Display or output (check one)

- | | |
|-----------------------------------|--|
| <input type="checkbox"/> Drifts | <input type="checkbox"/> Unable to zero |
| <input type="checkbox"/> Unstable | <input type="checkbox"/> Will not read applied input |
| <input type="checkbox"/> Overload | |

- | | |
|---|--|
| <input type="checkbox"/> Calibration only | <input type="checkbox"/> Certificate of calibration required |
| <input type="checkbox"/> Data required | |

(attach any additional sheets as necessary)

Show a block diagram of your measurement system including all instruments connected (whether power is turned on or not). Also, describe signal source.

Where is the measurement being performed? (factory, controlled laboratory, out-of-doors, etc.)

What power line voltage is used? _____ Ambient temperature? _____ °F

Relative humidity? _____ Other? _____

Any additional information. (If special modifications have been made by the user, please describe.)

Be sure to include your name and phone number on this service form.

Specifications are subject to change without notice.

All Keithley trademarks and trade names are the property of Keithley Instruments, Inc. All other trademarks and trade names are the property of their respective companies.



Keithley Instruments, Inc.

BELGIUM: Keithley Instruments B.V.
CHINA: Keithley Instruments China
FRANCE: Keithley Instruments Sarl
GERMANY: Keithley Instruments GmbH
GREAT BRITAIN: Keithley Instruments Ltd.
INDIA: Keithley Instruments GmbH
ITALY: Keithley Instruments s.r.l.
KOREA: Keithley Instruments Korea
NETHERLANDS: Keithley Instruments B.V.
SWITZERLAND: Keithley Instruments SA
TAIWAN: Keithley Instruments Taiwan

28775 Aurora Road • Cleveland, Ohio 44139 • 440-248-0400 • Fax: 440-248-6168
1-888-KEITHLEY (534-8453) www.keithley.com

Bergensesteenweg 709 • B-1600 Sint-Pieters-Leeuw • 02/363 00 40 • Fax: 02/363 00 64
Yuan Chen Xin Building, Room 705 • 12 Yumin Road, Dewai, Madian • Beijing 100029 • 8610-6202-2886 • Fax: 8610-6202-2892
3, allée des Garays • 91127 Palaiseau Cédex • 01 64 53 20 20 • Fax: 01 60 11 77 26
Landsberger Strasse 65 • D-82110 Germering • 089/84 93 07-40 • Fax: 089/84 93 07-34
The Minster • 58 Portman Road • Reading, Berkshire RG30 1EA • 0118-9 57 56 66 • Fax: 0118-9 59 64 69
Flat 2B, WILLOCRISSA • 14, Rest House Crescent • Bangalore 560 001 • 91-80-509-1320/21 • Fax: 91-80-509-1322
Viale San Gimignano, 38 • 20146 Milano • 02-48 39 16 01 • Fax: 02-48 30 22 74
2FL., URI Building • 2-14 Yangjae-Dong • Seocho-Gu, Seoul 137-130 • 82-2-574-7778 • Fax: 82-2-574-7838
Postbus 559 • NL-4200 AN Gorinchem • 0183-635333 • Fax: 0183-630821
Kriesbachstrasse 4 • 8600 Dübendorf • 01-821 94 44 • Fax: 01-820 30 81
1FL., 85 Po Ai Street • Hsinchu, Taiwan, R.O.C. • 886-3-572-9077 • Fax: 886-3-572-9031